



EZ2400
Operators Manual



Digi-Star★
Ft. Atkinson, Wisconsin USA
Digi-Star★Europe
Panningen, The Netherlands
www.digi-star.com

TABLE OF CONTENTS

TABLE OF CONTENTS.....	2
CAB CONTROL (WIRELESS).....	3
BEFORE CHARGING BATTERY OR WELDING	4
INDICATOR OVERVIEW.....	5
OPERATION.....	7
INDICATOR ON	7
ZERO BALANCE INDICATOR.....	7
TARE AND NET/GROSS	8
HOLD	10
PRINT KEY	10
FUNCTION AND SELECT	11
TIMER OPTION	12
USING THE M+, RM AND CM OPTIONS.....	13
PRINTING WEIGHT FROM MEMORY	15
WEIGHT AVERAGING.....	16
PRINTING AVERAGE WEIGHT.....	17
USING DIMMER OPTION.....	17
MENUS AND CALIBRATION	18
MENU 1. BASIC FEATURES IN MOST INDICATORS.....	18
MENU 2. CLOCK, PRINTER,.....	19
COMMUNICATIONS FEATURES.....	19
MENU 3. SCALE CALIBRATION SETTINGS	20
MENU 4. PRESET, BATCHING & ROTATION COUNTER FEATURES ..	20
CALIBRATION	20
CHANGE SET UP AND CALIBRATION NUMBERS.....	21
TROUBLESHOOTING.....	22
INSTALLATION	24
INDICATOR MOUNTING	24
LOAD CELL DIRECTION.....	24
CABLE CONNECTION	25
CONNECT LOAD CELLS TO J-BOX.....	26
OPTIONAL EQUIPMENT	27
DATA TRANSFER OPTIONS	27
TRANSMITTER/RECEIVER.....	27
REMOTE INDICATORS.....	27

Cab Control (Wireless)



Features

- Wireless remote with full key control of indicator on mixer
- Mount remote in easy view of loading
- Improves loading accuracy

Functions

- Communicates with multiple mixers

Specification

- Internally mounted 2.4 GHz radios
- Up to 1000 foot range
- 24 channels
- 12 or 24 volt DC system

For additional information go to www.digi-star.com

Before Charging Battery or Welding

Important Precaution



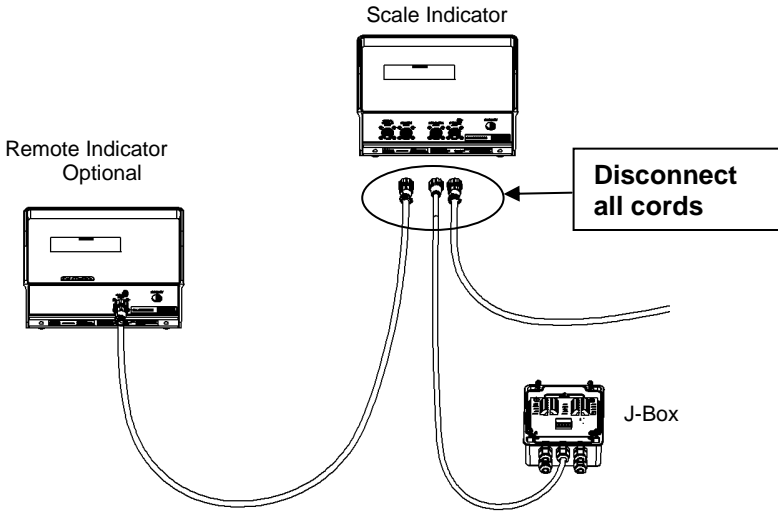



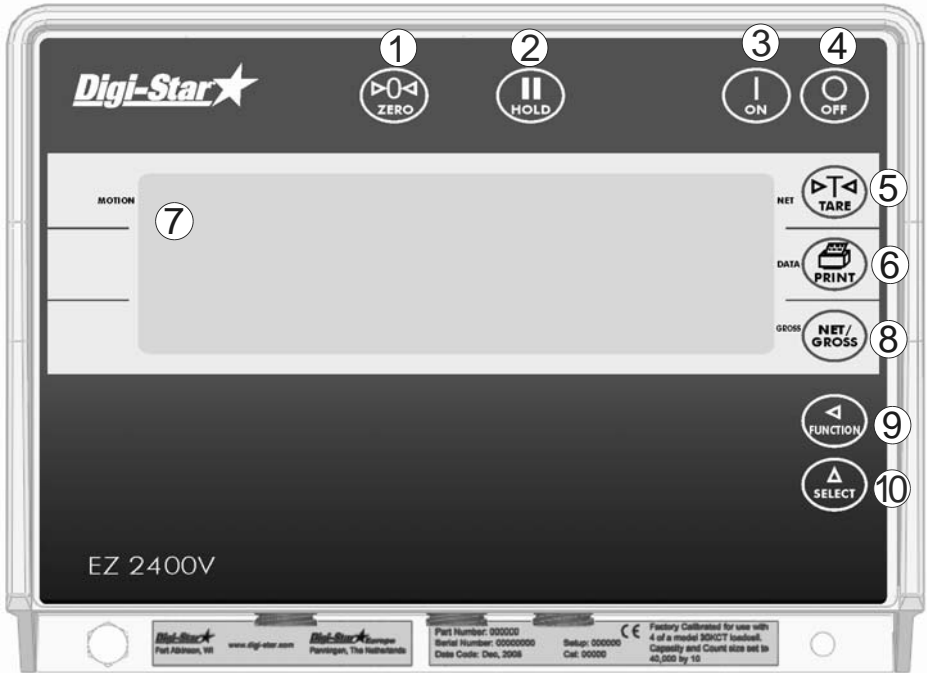

Disconnect all indicator leads before charging battery or welding. Damage may occur to indicator and load cells.



INDICATOR OVERVIEW



Note: See page 24-26 for installation instructions

- ①  – press and hold for 3 seconds to zero balance indicator.
- ②  – holds displayed weight press to release.
- ③  – turns indicator on. Press while on runs self test.
- ④  – turns indicator off.
- ⑤  – temporary zero (Net Mode).
- ⑥  – records to memory or prints displayed weight.
- ⑦ Display Window – Displays current actions.
- ⑧  – toggles between Net and Gross weights.
- ⑨  – performs task displayed by select.
- ⑩  – displays additional tasks.

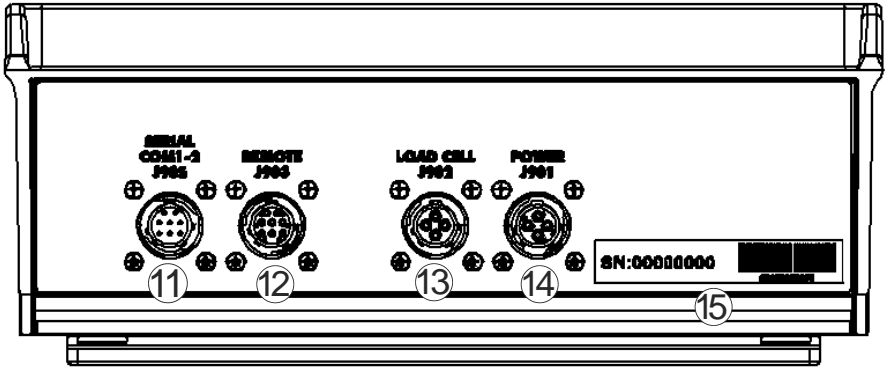



- ⑪ Serial/Printer Port- optional, to communicate with computer and other digital input/output devices.
- ⑫ Remote Port – optional, for remote display.
- ⑬ Load Cell Port – for J-Box cord.
- ⑭ Power Port – for power cord.
- ⑮ Serial Number Plate – Serial Number of indicator.

OPERATION

Indicator On

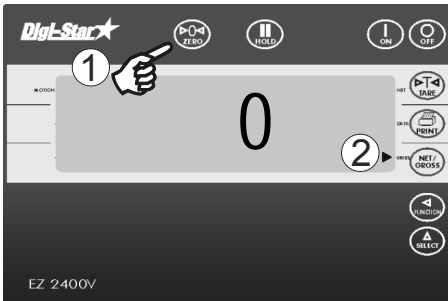
1. Press .

Zero Balance Indicator

1. Press and hold  for 3 seconds to zero balance indicator.
2. Flashing arrow points to gross next to the display window, indicator ready to weigh.

Tare and Net/Gross

Tare is a temporary zero (Net Weight)
to display total weight (Gross Weight)

Press 

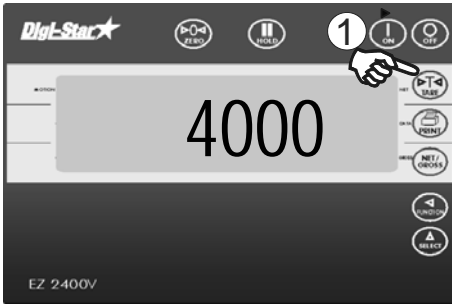

1. Weight displayed, press  sets zero weight.

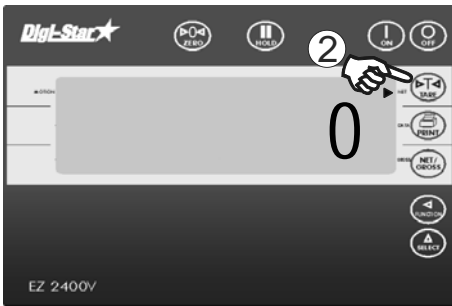

2. Pressing  displays zero weight and flashing arrow on side of display points to NET.

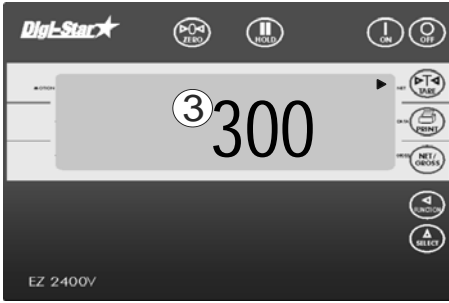

3. Add more weight.



4. To know total of original weight of 4000 pounds plus added 300 pounds, press **NET/GROSS** to show 4300 pounds flashing arrow points GROSS.



5. Press **NET/GROSS** 300 pounds displayed flashing arrow points NET.

Hold

Hold mode prevents displayed weight from changing while moving.



1. Press .
2. Press  indicator normal.

If weight added in hold mode, press  to cancel hold.

Print Key

Requires optional serial port



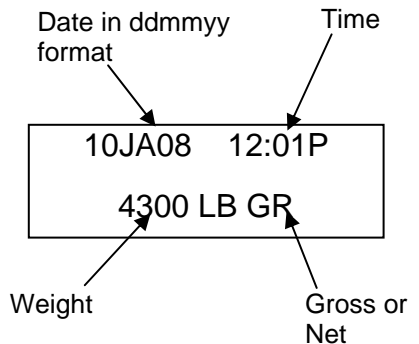

1. Press . Indicator sends data to printer or PC.

Sample output format shown below:

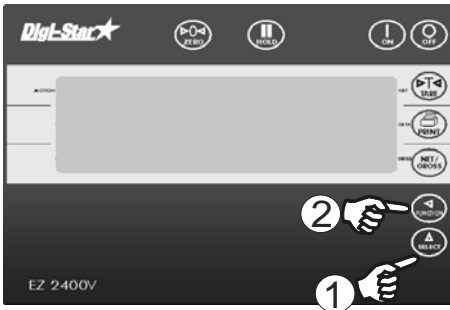

Function and Select



1. Repeatedly pressing  gives following options:

Timer: Stopwatch for mixing time

M+: Adding weigh to weight memory

RM: Recall weight memory

CM: Clear weight memory

Dimmer: Dimming backlight

Menu: View menus 1,2,3,4 and calibrate. See pages 18

Setup: Change setup and calibration numbers. See page 21

Help: Explains operation of select and function key

2. Desired option displayed, press  to activate.

Timer Option

Stopwatch for mixing time.





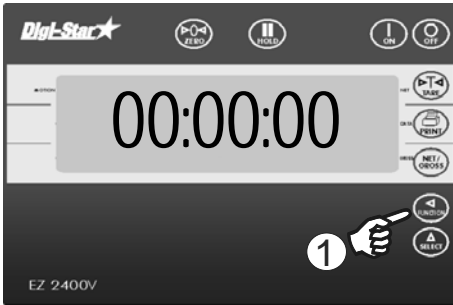

1. Repeatedly press  until TIMER is displayed.



1. Press  to displays hours, minutes and seconds. (hh:mm:ss)



1. Repeatedly press  moves flashing digit left.
2. Repeatedly press  changes number.
3. Press  to start timer.
4. When timer reaches zero press  to clear timer.

Using the M+, RM and CM Options

Use these options to weigh truck or wagon one axle at a time.

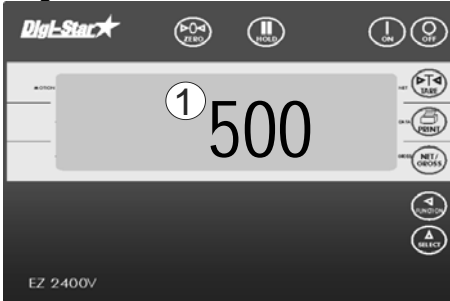

1. Add weight on scale. Example: 500 pounds.



2. Repeatedly press  until M+ is displayed.

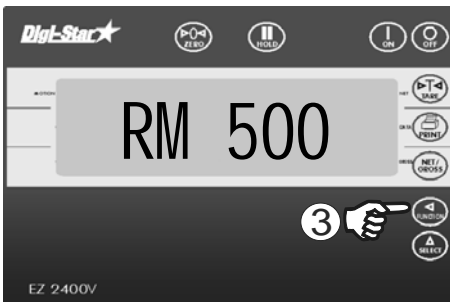

3. Press  500 pounds and RM briefly displayed 500 pounds added to indicator memory and indicator in gross weight mode.

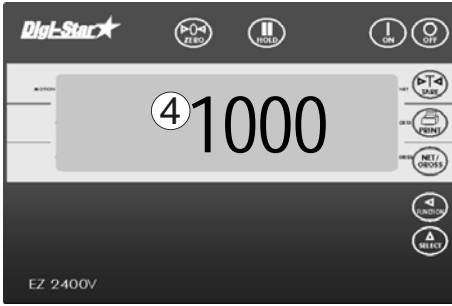

4. Put another weight on scale.
Example: 1000 pounds.



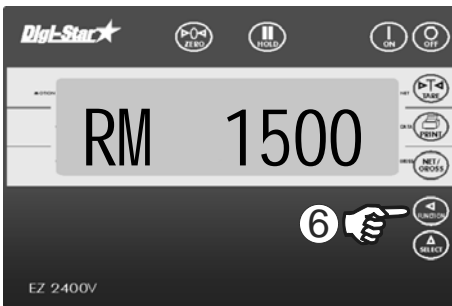

5. Repeatedly press  until M+ is displayed.

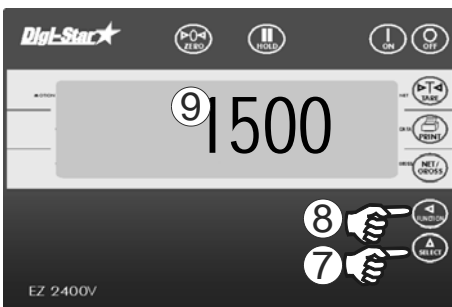

6. Press  indicator adds 1000 pounds to 500 pounds in memory and RM flashes.



7. Repeatedly press  until RM is displayed.
8. Press .
9. Total of both weights, 1500 pounds, displays, indicator switches to gross weight mode.

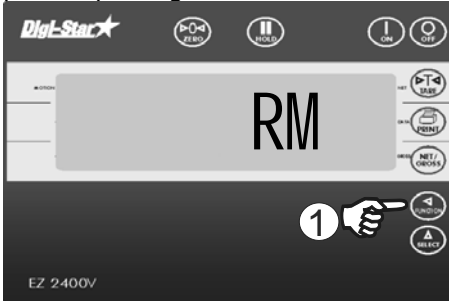

Printing Weight from Memory

Indicator must have optional printer port for printing.





1. Repeatedly press  until RM displayed.

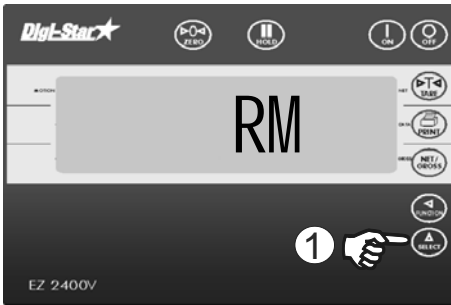

2. Press  shows weight in memory. Example: 1500 pounds.
3. Press  while weight displayed.

Weight Averaging



1. Repeatedly press  until RM displayed.



2. Press  twice within three seconds performs weight average.
3. Display shows COUNT 2 if number of individual weights to average is two. Example weight of 1000 pounds and 500 pounds averaged.



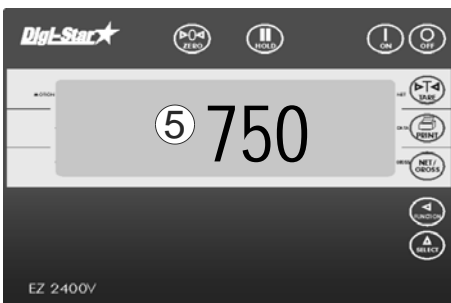

4. Displays AVERAG.

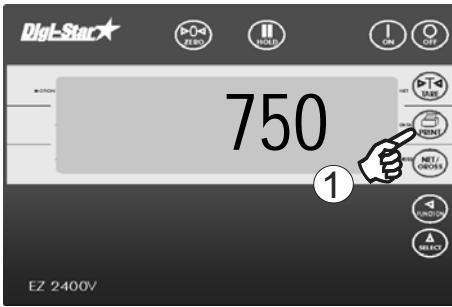

5. Display shows average of two weights in memory. After displaying average weight, indicator returns to gross weight mode.

Printing Average Weight



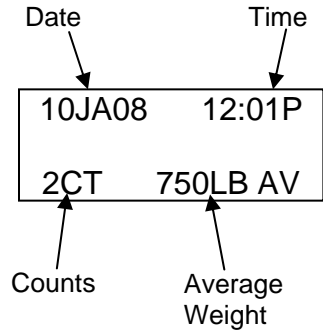

1. Press  while average weight is displayed.

Sample output format shown below:









Using Dimmer Option



1. Repeatedly press  until DIMMER is displayed.
2. Press  dims backlight.

MENUS AND CALIBRATION

Options changed by user. To display menus 1,2,3,4 and calibrate:

1. Repeatedly press  until MENU is displayed.
2. Press .
3. Repeatedly press  selects Menu1,2,3,4 or calibrate
4. Press  displays setting name and allows value changes.
5. Press  selects options for each setting/display.
6. Press  saves setting and next option for menu displays.

SETTING/ DISPLAY	D.A.N NO.	OPTIONS BOLD=DEFAULT	DESCRIPTION
MENU 1. BASIC FEATURES IN MOST INDICATORS			
LANGUAGE {l angag}	101	English(ENGLISH) (NEDERL) French (FRANCS) Dutch(DEUTSH) Italian (I TAL) Portuguese (PORT) Spanish (ESPAN) Danish (DANSK) (MAGYAR) (VESTA)	Select language to be displayed.
DISPLAY RATE {0 rate}	102	1,2,3,4	Update display times per second.
ZERO TRACK {ztrack}	104	ON/OFF	If ON -zero track adjust balance for build up of snow & mud.
WEIGH METHOD {W mthd}	105	1=General, 2=Fast, 3=Slow, 4=Lock-On	Select weigh method
SCALE ID SETUP {scal id}	108	NEW EZ	Identity of scale location (truck id or Mixer number).
1 PRESS ZERO {1 zero}	115	ON/OFF	If ON -press and hold Zero key to Zero/Balance scale.

SETTING/ DISPLAY	D.A.N NO.	OPTIONS BOLD=DEFAULT	DESCRIPTION
MENU 2. CLOCK, PRINTER, COMMUNICATIONS FEATURES			
TIME FORMAT {time f}	201	24 HR AM/PM	Select time format -AM/PM or 24 hour
1 TIME {time}	202	XX:XX:XX	Select key changes time, function key chooses hh:mm:ss.
DATE FORMAT {date f}	203	1-mm-dd 2-mm/dd/yy 3-mm/dd/yyyy 4-dd-mm 5-dd/mm/yy 6-dd/mm/yyyy 7-ddmoyy 8-ddmoyyyy.	Select date format
DATE {date}	204	Enter XXXXXX	Select key changes date -function key chooses mm/dd/yy .
TARE AUTO PRINT {tareap}	211	ON/OFF	If ON -tare auto-prints displayed weight.
ONE LINE PRINT {1l prt}	212	ON/OFF	If ON -indicator data prints on one line.
AUTO PRINT {aprint}	214	ON/OFF	If ON -pressing keys auto-prints weight values.
PRINT FORMAT {prtfmt}	216	AUTO WTONLY DOWNLD DT+TM ID+TM IDWTTM ANIMAL 3200-A 3200-B 32-TMR DATCH1 FDINFO WTRCTM EIDINF EID EIDVID	Select alternate & comma (CSV) formats.

SETTING/ DISPLAY	D.A.N NO.	OPTIONS BOLD=DEFAULT	DESCRIPTION
REMOTE REMOTE	218	ON/OFF	If ON indicator communicates with cab control display
ZERO OUTPUT {zerout}	219		Perform Zero/Balance for SCOREM #11 weight output and analog output (4-20mA)
SCALE NUMBER {scl no}	231		Select scale number for cab control communication
REMOTE DISPLAY rmdi sp	234	EZ3MUX EZ2	Select type of remote display
ANALOG LOW WEIGHT LOW WT	241		Enter analog weight value to equal 4mA or 0 volts
ANALOG HIGH WEIGHT HI GHWT	242		Enter analog weight value to equal 20mA or 5 volts
ANALOG SELECT ANAOUT	243		Select 0-5V,4-20ma or 0-20ma output

MENU 3. SCALE CALIBRATION SETTINGS

DISPLAY UNIT {lb-kg}	301	.01,.02,.05,.1,.2,. 5,1,2,5, 10 ,20, 50,100	Select display count size of weigh values.
CAPACITY {cap}	303	LB/KG	Display pounds -lb or kilograms -kg
WM1 ADJUST 1 {wma1-1}	304	40000	Enter MAXIMUM weight measurable on scale.

MENU 4. PRESET, BATCHING & ROTATION COUNTER FEATURES









Does not apply to 2400 indicator

CALIBRATION

DEAD WEIGHT CAL {CAL}	802		Calibration method using weights
SETUP NUMBER SETUP	871		Quick entry method selects weigh method 1-4lbs, 5-8 kg, gain 1-9, display counts 1-9 and capacity *1000
CALIBRATION NUMBER CAL	872		Weight displayed at 0.4mV/V for these load cells

Change Set up and Calibration Numbers



1. Repeatedly press  until SETUP is displayed.
2. Press .
3. Six digit setup number displayed. Change number, press  moves flashing position left. Press  changes number.
4. Press  stores setup number. Indicator displays CAL, change number by pressing  and .
5. Press  to exit.

TROUBLESHOOTING

FLOW CHART

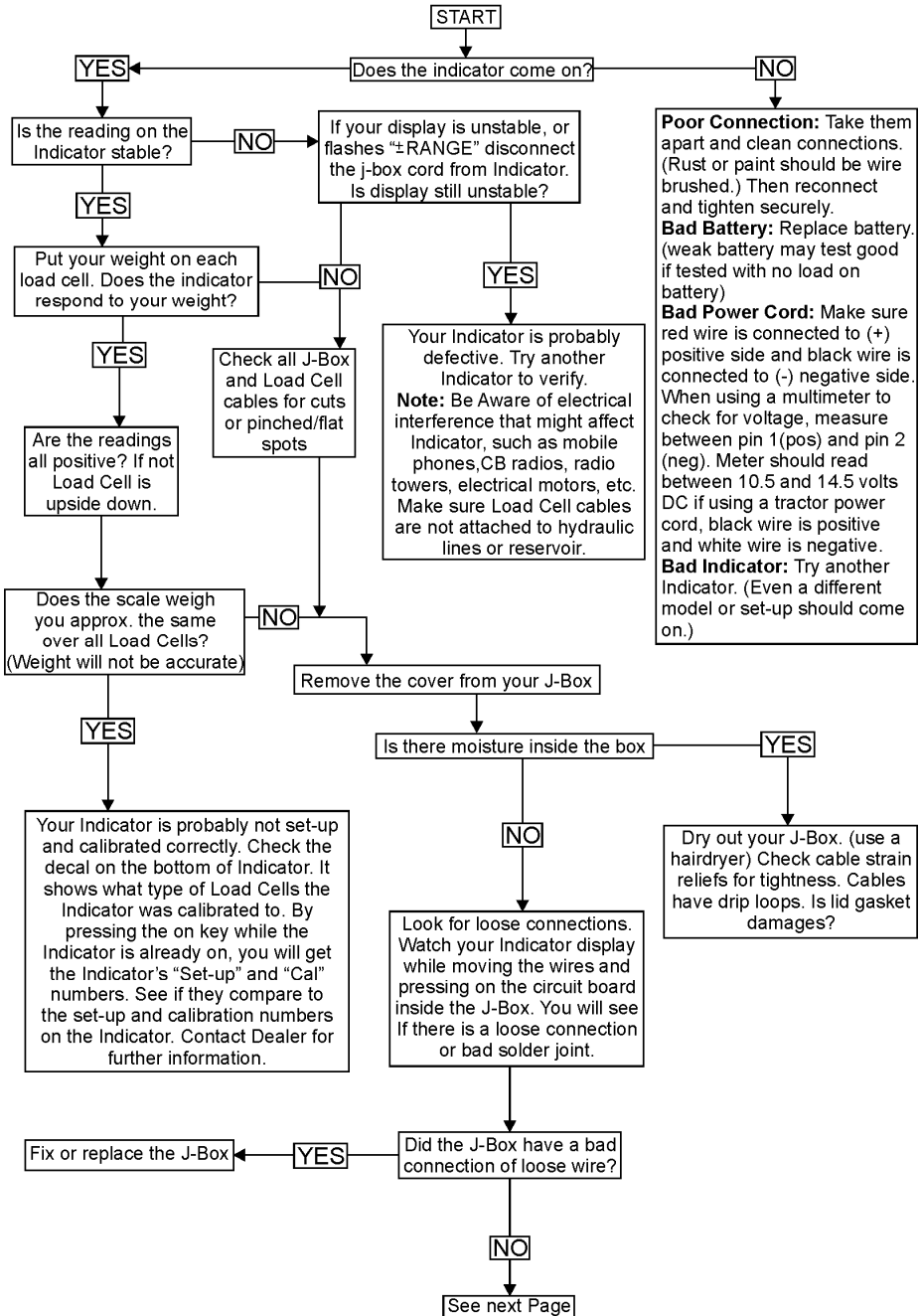

FLOW CHART

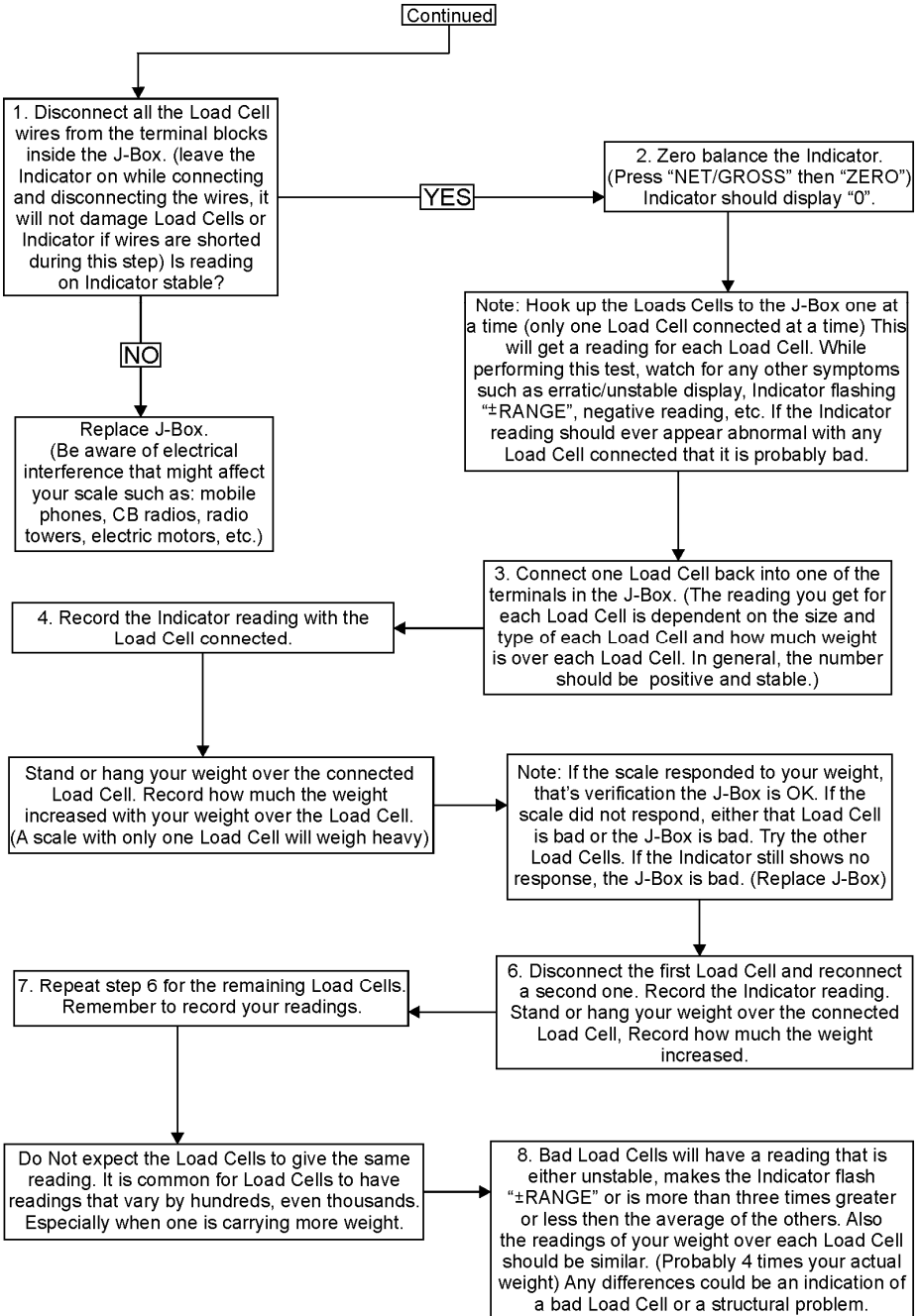

INSTALLATION

Indicator Mounting

Rail Mount
Included

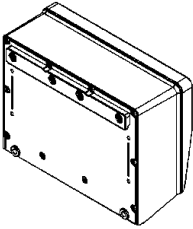

Wing Mount
Included

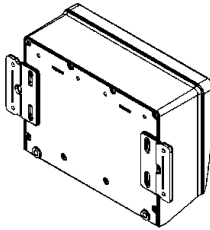

RAM Mount
Optional

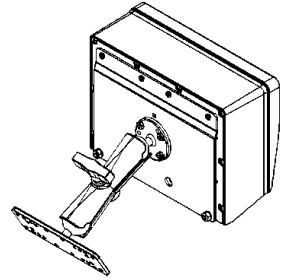

Rail Mount (Standard) and Wing Mount w/ hardware included.
RAM Mount Optional Kit, hardware included w/ kit.

Load Cell Direction



Observe direction of arrow when installing load cell.

Cable Connection

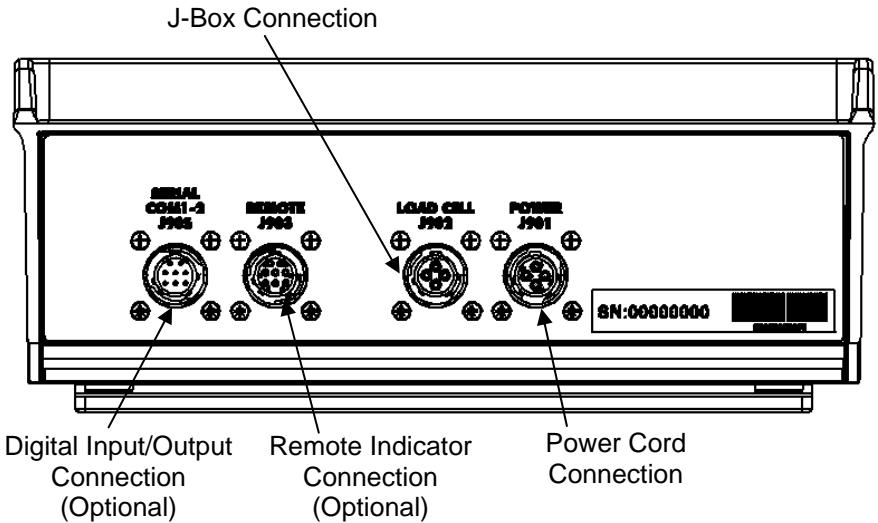
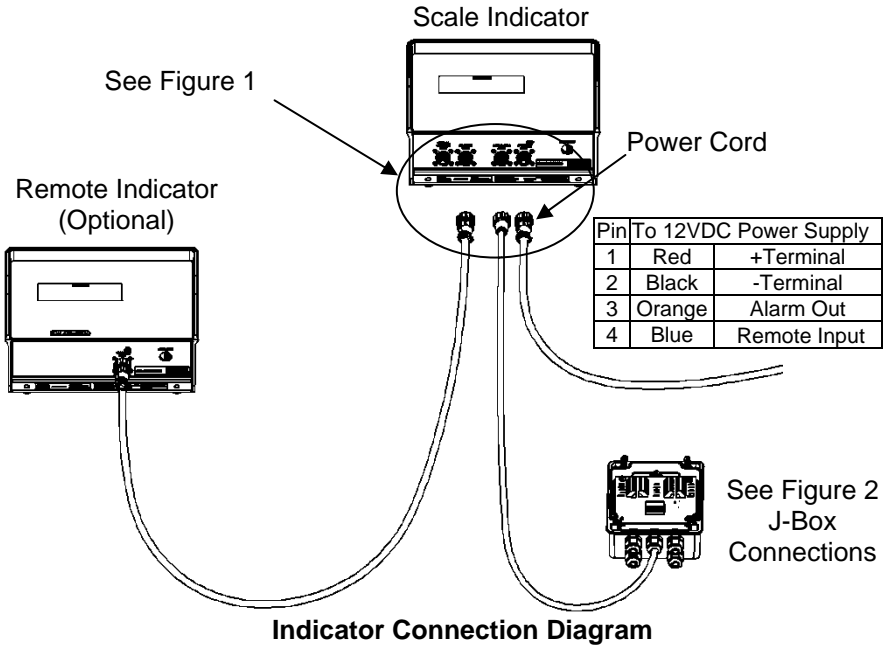
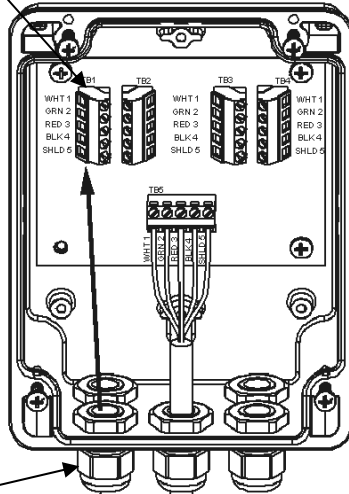

Figure 1 Bottom Panel Cable Connections

Connect Load Cells to J-Box

Connect load cell wires to terminal blocks.
See Wire Color Key

Wire Color Key		
	Color	Description
1	White	Signal +
2	Green	Signal -
3	Red	Excitation +
4	Black	Excitation -
5	Shield	Shield



J-Box Illustrated for 4 Load Cell Installation

J-Box Cable

Tighten Nuts

Load Cell Cable

Connect to Indicator bottom Panel.
See Figure 1.

Figure 2 J-Box Connections

OPTIONAL EQUIPMENT

Data Transfer Options



Kit Data Down Loader

Allows transfer of data from indicator to PC. (Optional communication port must already be installed in indicator)

Transmitter/Receiver



Transmitter (shown) with factor installed receiver in indicator. Use to zero indicator from a remote location. Operating range about 90 feet.

Remote Indicators



RD440 small remote display

RD2400V backlit remote display with 1.7" high numbers

RD2400V backlit remote display w/transmitter and installed receiver

RD2400 backlit remote display with 1" high numbers

RD2400 backlit remote display w/transmitter and installed receiver

RD4000 remote display