

# SEED SENTRY

---

---



Operator's Manual

Dear Purchaser,

Congratulations on your decision to purchase a "Seed Sentry Monitor System". This system will give you many years of service and can save you thousands of dollars by alerting you to the fact you are running out of seed or have had a mechanical breakdown. This unit features an internal computer and will monitor one to four rows. The compact size and easy operation makes this system ideal for many seed flow monitoring applications.



©1997 Agri-Tronix Corporation

All rights reserved. No part of this publication may be reproduced, transmitted, transcribed, stored in a retrieval system or translated into any language in any form by any means without the written permission of Agri-Tronix Corporation.

# Warranty

**This System is under warranty against defects in material or workmanship for a period of two years from the date of retail sale.**

Defective monitors must be returned to the place of purchase within the warranty period. Components will be replaced or repaired at factory discretion. This warranty applies only to those systems which have been installed in accordance with published instructions.

This warranty is in lieu of all warranties, expressed or implied, and the manufacturer expressly disclaims all other warranties, including without limitations any implied warranties of merchantability and fitness for a particular purpose.

The manufacturer liability under this warranty shall not exceed the cost of the product. Under no circumstance shall the manufacturer be responsible for equipment on which it's monitors are installed, field service calls relating to this equipment or for indirect, consequential or special damages.

Authorized warranty center:

**Agri-Tronix Corporation  
2001 North US 31  
Franklin, IN 46131**

# Wiring Diagram

Below is the wiring diagram for the 37 pin connector:

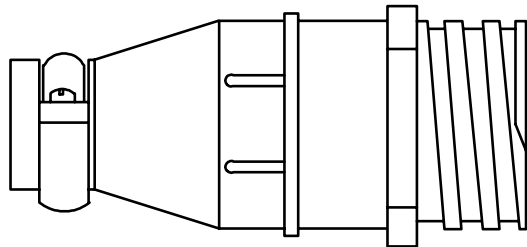

Optional pinout for "CT" versions

|    |    |                   |
|----|----|-------------------|
| 1  | 1  | Signal Input 1    |
| 2  | 2  | Signal Input 2    |
| 3  | 3  | Signal Input 3    |
| 4  | 4  | Signal Input 4    |
| 24 | 27 | Vcc (8 volts out) |
| 26 | 28 | System Ground     |
| 34 | 34 | Ground            |
| 35 | 35 | Ground            |
| 36 | 36 | Ground            |

*If your unit has the letters "CT" in the serial number use the pin numbers in the second column.*

# Console Installation

1. Select a rigid surface in the cab area to mount the console. The display should be mounted in a location that can be easily seen while looking straight ahead from the driver's seat. Also, make sure there is room to route the monitor harness to the rear of the tractor.
2. (Before drilling holes, make sure there are no cables or objects behind the panel that could be damaged by the drill bit.) Using the mounting bracket as a template, mark and drill two 1/2 inch holes. (Do not drill a hole larger than 1/2 inch or the well nuts will not tighten in the hole.) Mount the bracket as shown in the above figure. Use the 1/4-20 bolts and rubber well nuts provided in the hardware kit. If you should decide not to use the well-nuts, drill two 5/16 inch holes and use the 1/4-20 hex nuts and lock washers included in the hardware kit.
3. Route the cable to the rear of the tractor being sure to locate the cable so as to clear all moving parts and hot hydraulic lines. Use the nylon straps and either the 8-32 screws or self tapping sheet metal screws to securely mount the cable.

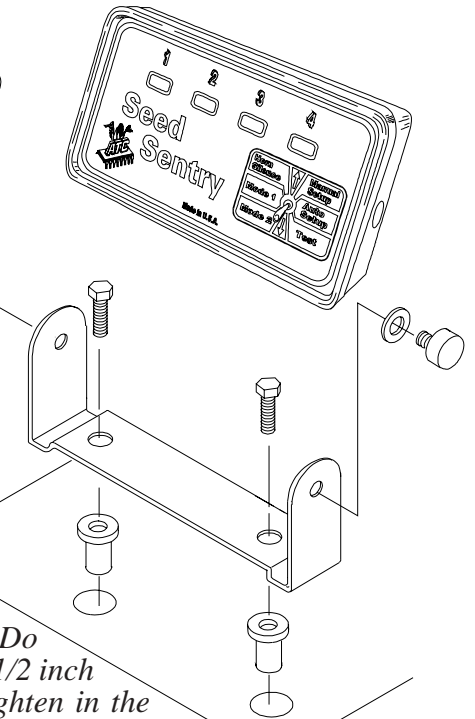

*This unit is equipped with an over-current protection device that will reset automatically when the overload is removed. The lights are light emitting diodes and have an average life of over 15 years. There are no user serviceable parts inside this unit.*

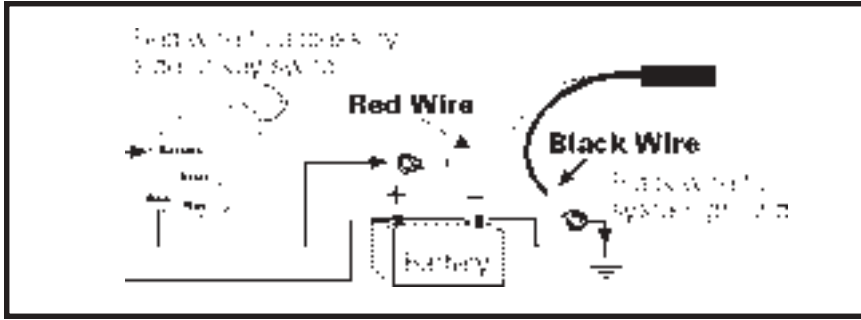

4. Connect the black wire to the vehicle's electrical ground. (You can run a wire directly to the ground post of the battery or find an area in the cab where the connector can be bolted to bare metal) The red wire is connected to a terminal on the 12-volt accessory side of the electrical system.

**IMPORTANT!** You must be connected to a terminal that disables the 12 volts when the key is in the "off" position. This monitor system will discharge your battery over a period of time if power is not disconnected when not in use.

6. Next locate the Seed Sensor Harness and attach to your implement. Take care to install the cable so it will not be pinched or damaged by moving parts. Use the tie-raps and nylon clamps provided in the hardware kit to securely fasten the cable at least every 3-feet.
- 7 This completes the installation of your console and harness.

## Operation

Once the monitor has performed the power up procedure and the seeds start planting, the monitor will alarm when the population drops below 50% of the "setup reading". During an alarm condition the horn will sound continuously and the light will stay on. Once the monitor alarms, the population must return to 75% of its "setup reading" to turn the alarm off.

**Note!!! Keep in mind that if you set your drill up while planting at 6 mile per hour, if you slow down to 3 miles per hour your monitor will alarm. If this is a problem in your application then set the unit up while planting at a slower speed.**

The switch on the front panel controls the display mode and will silence the alarm during a failure condition. When the switch is in "Mode 1" the indicator lights will flash each time a seed passes the seed sensor. When the switch is in "Mode 2" a light will be on only when there is an alarm condition.

During an alarm condition the horn can be silenced by momentarily holding the switch in the up position.

When all enabled rows have an alarm condition, the horn will silence after 2 seconds and all enabled row lights will remain on. (The monitor assumes you have stopped planting.)

# Automatic Setup

This monitor was designed to monitor 1 to 4 seed sensors and give a visual and audio alarm when any seed sensor drops below 50% of the population that was recorded during the “setup procedure”. This unit is designed for easy setup and will configure automatically for the number of seed sensors connected to the system. Once the monitor has been configured it will retain this information until the setup routine is performed again. (This monitor retains “setup” information with power removed and requires no internal batteries.)

The control switch located on the front panel of the monitor is used for several functions. The legend is divided in half, the left side controls the display mode and will silence the horn. The right side is used for setup and testing of the system.

To perform the “Automatic Setup”, the system must be hooked up and you must be planting. To initiate "Automatic setup, hold the switch in the up position (Manual Setup) until the horn beeps twice. Release the switch after the second beep and the unit is now in “Auto Setup”. ( If you accidentally press the switch all the way down into the “Test” position the unit will enter “Test Mode”.( If this happens, hold the switch in the up position until the horn beeps twice.)

As soon as the monitor calculates the alarm point for a seed sensor the light for that row will illuminate (this calculation could take up to 30 seconds on a low population condition.) After the alarm points have been calculated, the monitor saves these values in memory, turns the lights off, beeps the horn 3 times and enters “Mode 1” of normal operating mode. Your system is now ready to use.

**Note!!!** It is not possible to set alarm points in the manual mode, this must be done in the “Auto Setup” mode. The alarm points will remain from the last auto setup, to change the alarm points you must perform “Auto Setup”.

# Seed Sensor Installation

## Seed Sensors for drills

1. The seed sensors for drills will consist of one of the following types:

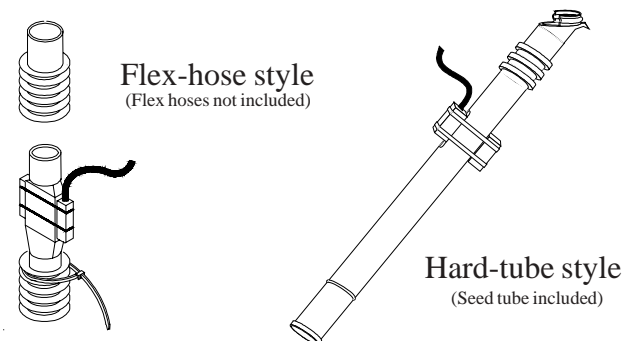

2. The common practice for drill monitors is to monitor the two end rows of your drill. When the grain in the seed boxes gets low, normally the end rows run out first. If your drill is equipped with flex hoses for the seed drops, cut the flex hose in half and install the sensor tube with the seed sensor wire pointing towards the seed boxes. Mate the connectors to the drill harness.
3. If you have a drill with the hard seed tubes, remove the original tubes from the end rows and replace them with the tube supplied with your system.

## Seed Sensors for Planters

1. Remove the original seed tubes from you planter and replace them with the seed tubes and sensors included in your system. Your seed tubes may vary from the picture depending on what style planter you have.

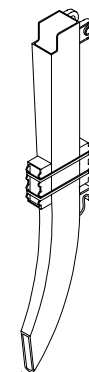

# Switch Legend

Below is brief description of the different functions the control switch on the front panel serves. In normal operating mode the functions on the left side of the legend are used.

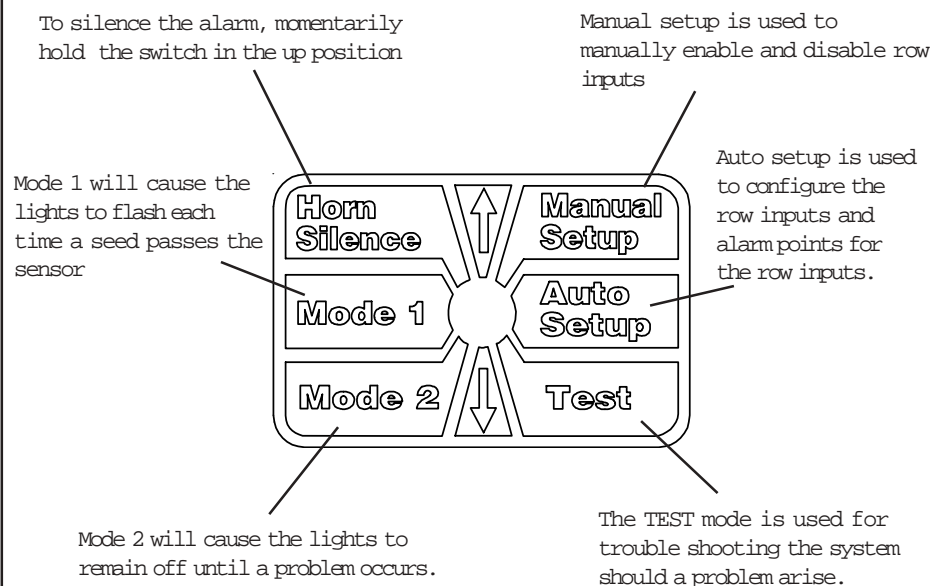

**A more detailed description of the control switch follows on the next few pages.**

# System Test

1. After checking to be sure all connectors are mated properly and the power leads have been connected, turn on the key and the display will give a short signal on the alarm. The computer will perform a self check and the lights on the display will advance from left to right. The unit will next display all inputs that are enabled. (The unit comes pre-configured from the factory)  
If the unit did not power up make sure the red wire is connected to positive 12 volts and the black wire has a clean, tight connection to ground.
2. The next step is to check the system for proper operation. With the tractor key on and the unit powered up, place the switch in the up position until the horn beeps twice. ( must be held for approximately five seconds) Next place the switch all the way down into "Mode 2".
3. Go to each of the seed sensors and drop some kernels of grain down the seed tube. If everything is connected properly the horn will sound and the light will flash off and on each time the seed sensor detects grain. You can also momentarily short the green and black wire together to send a signal pulse to the console.
4. If the monitor does not respond, disconnect the seed sensor and momentarily short the black and green wires on the drill harness together. If the light flashes on the monitor, there is a problem with the seed sensor or the 8 volts needed to power up the sensor is not present. With 12 volts applied to the monitor, there will be 8 volts between the black and red lead on the drill or planter harness.
5. To exit "Test Mode" place the toggle switch in the "Mode 1" position. This completes the system test.

