

Contents

Installing the console	2
Installing the wiring harness	3
Installing power and distance cable	3
Gear tooth sensor Installation	4
Data selector knob function	5
Flow chart of setup screens	6,7
Placing the console in setup mode	6
Erasing "Saved Pull Distances"	8
Perform distance calibration	9
Manually edit distance calibration	10
Auto switch of calibration numbers	11
Setting "Mile Per Hour Limit" alarm	12
Change display units	13
Testing the relay circuit	13
Enable radio link	14
Set as receiver or transmitter	15
Set radio channel	16
Test radio signal strength	18
Console wiring diagrams	19
Console power-up Screens	19
Console measuring mode screens	19
Console run-mode screens	20
Remote console setup	22
Establish radio contact	23
Signal strength	24
Remote console operation	25
Common questions	26-27
Warranty	28

This manual was written with software Version 3.9 in effect. Please check our website for the latest software version available.

<http://www.agri-tronix.com>

Console Installation

Installing the Console

The console should be mounted in a location that the operator can easily see and operate the data selector knob. The M3 bracket is designed so that it may be top-mounted with the bracket overhead or bottom-mounted with the bracket underneath. (Consoles with radio boards have an antenna extending from the top of the unit)



Top mount



Bottom mount

To mount the bracket:

Using the bracket as a template, mark two holes and drill two 3/8" holes.



Before drilling two 3/8" holes to mount the bracket, check to be sure there are no wires, tubing or hoses behind the surface that would be damaged by the drilling operation.

Using the mounting 5/16" bolts supplied, fasten the bracket to the surface and attach the console using the bracket knobs.

<i>Description</i>	<i>Part Number</i>
Mounting bracket for distance sensor	1000-5723
Mounting bracket knobs (2), well nuts (2)	1000-6970
Power input lead	1000-3795
Gear tooth sensor kit (Bracket and sensor)	1000-6525
Gear tooth sensor only	1000-6515
Distance sensor cable	1400-7108-12
Relay wiring harness	1000-6801
Base plate for remote display	1000-6654
AC/DC power pack for remote display	1000-1678

Harness Installation

Installing the Wiring Harness

The console is built with connectors on the rear of the unit so the monitor can easily be removed and stored when not in use. The wiring harness contains the relays that are used to operate the external alarm and staging circuit.

The staging relay has a normally open contact that closes when the monitor is "staged" and ready to measure. This is a very useful feature that can be wired into the green light indicator circuit already on the sled. This feature ensures that the sled monitor was placed in measuring mode before each individual pull starts.

Installing Power and Distance Cable

A power lead is supplied with the monitor that connects to a 10-16 volt DC power source. Connect the red lead to a positive 12 volts and the black lead to the negative side of the battery. (In most applications this would be chassis ground). Connect the 4-pin power connector to the middle connector on the back of the console.



Do not connect the console power leads to 24-volt systems or 6-volt systems.

Connect the cable that leads to the distance sensor to the 4-pin connector located next to the heat sink.

Turn the power switch (located on rear of unit) to the ON position. The backlight of the display will illuminate and the M3 will start performing a routine start up. If the unit is connected to an electrical connection that is powered by a key switch, it will be necessary to turn on the key switch to supply power to the console.

Rx/Tx Notes

The remote displays are supplied with a 110 volt wall adapter that plugs directly into the power connector.

Thermal Heatsink

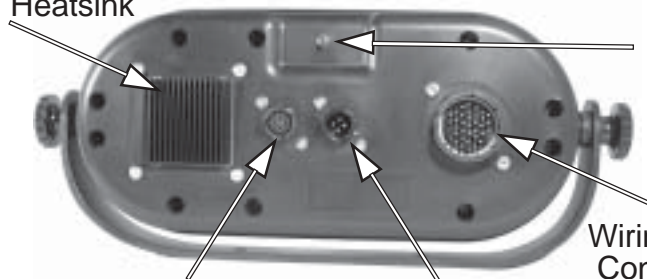

Distance Connector Power Connector

Rear view of M3 console

Gear Tooth Sensor

Gear Tooth Sensor Installation

Installation of the electronic gear tooth sensor varies depending upon the application. Since all sleds are built different, it is not possible to document every mounting application. Instead the following parameters are supplied that will act as a guide in installing the gear tooth sensor.

1. The sensor must be mounted as shown in fig A. *Do not install the sensor with the end facing the side of the sprocket.*

2. A universal mounting bracket has been included to mount the gear tooth sensor. **If building your own bracket, the bracket must be non-ferrous material for optimal performance.**

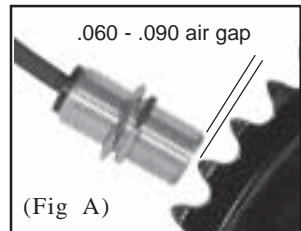

3. The distance from the face of the sensor, to the tooth on the sprocket should be the thickness of a quarter. (.060 to .090)

4. The gear tooth sensor must be mounted solid enough so that the air gap distance does not vary.

5. After mounting the sensor the 3-pin connector from the gear tooth sensor connects to the 3-pin connector on the console wiring harness.

NOTE: It is suggested that at least a 60 tooth sprocket be used when monitoring the rotation of the differential drive shaft for distance input. The sprocket must also be steel. (Aluminum or Stainless will not work)

After mounting sprocket, check alignment of sprocket so that it does not wobble and has no more than .050 inch runout.

Be sure the sensor clearance does not change as the sled springs are compressed. Damage to the sensor and sprocket could occur.

Overview of Setup

Setup Mode

Erase Memory
Drive Dist. Cal 1
Drive Dist. Cal 2
Edit Dist. Cal. 1
Edit Dist. Cal. 2
AutoSwitch CAL?
Edit Mph Alarm 1
Edit Mph Alarm 2
Edit Mph Alarm 3
Edit Mph Alarm 4
Distance Units
Test Relay
5th Wheel Option
Enable Radio
Change Mode
Change Channel
Change Band?
Setup Remote?
Signal Strength

Enter "Run Mode"

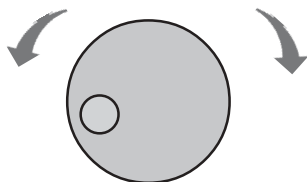

Rotate knob to select different data



Press in and release the knob to select an option

Run Mode

Ready
Save
Discard
Alarm (Off,1,2,3,4)
Cal #
Recall
Max Pull



Rotate knob to select different data



Press in and release the knob to select an option

Setup

To Enter Setup mode turn off unit, hold control knob in and turn unit on, release knob when setup screen appears.

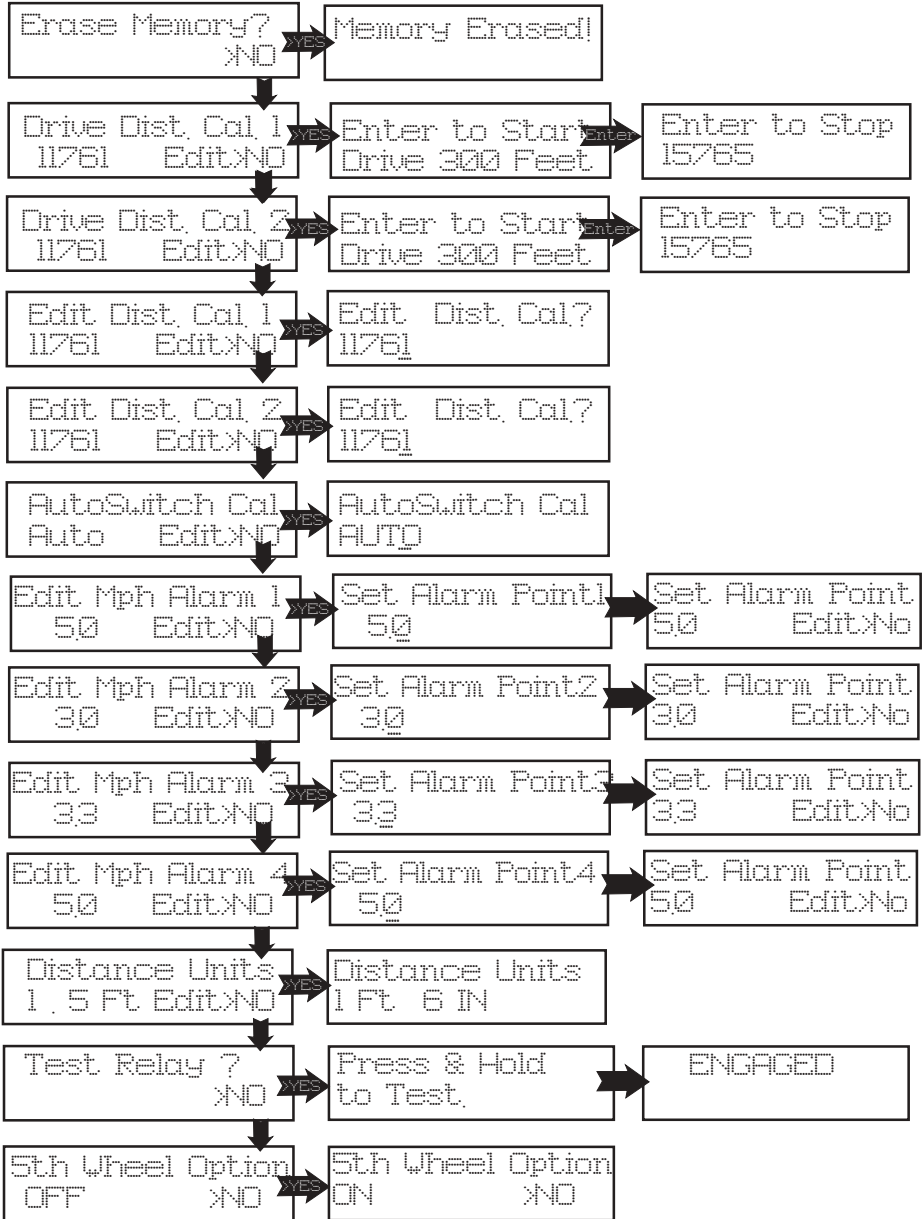

SETUP is continued on next page

Setup

If "Enable Radio" is set to "NO" then the following selections will not appear.

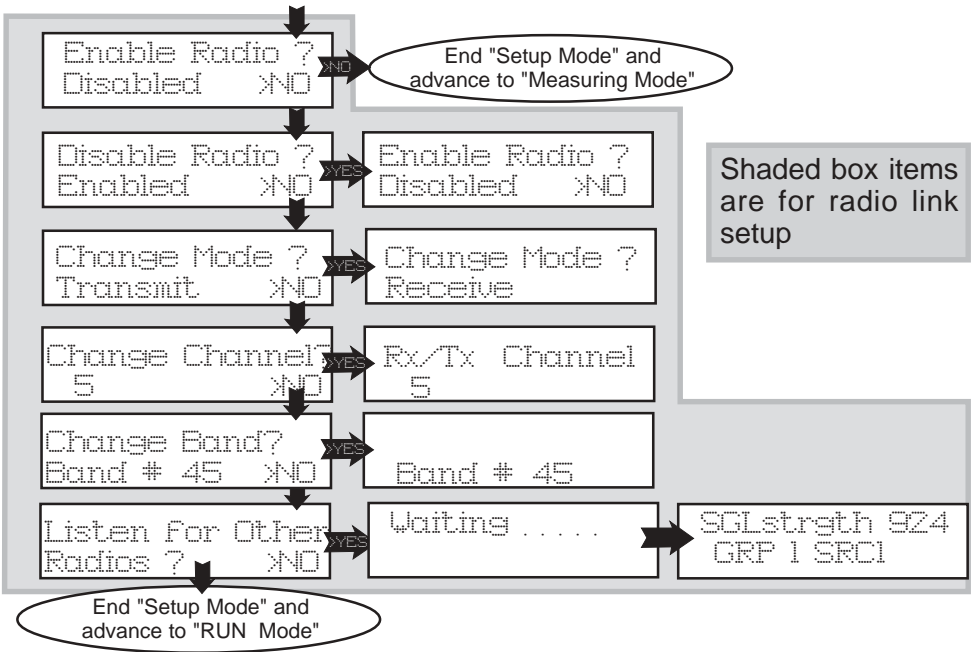

Setup

Erasing "Saved Pull Distances"



Information line

To delete data, rotate the data selector knob until the display reads YES, then press in and release the data selector knob. To select next parameter, rotate data selector knob until display reads NO, press in and release knob.

The sled and remote console will save up to 100 pull distances and the maximum speed achieved during each pull into a nonvolatile memory circuit. (The memory will actually save 115 pulls) The *nonvolatile memory* means that the console can be turned off, disconnected from power and the values will be retained and available for review the next time the console is powered up.

This setup screen allows the user to erase all saved pulls from the nonvolatile memory.

The "saved distances" can be erased by rotating the data selector knob until the word "Yes" appears in the lower right screen. Press in and release the data selector knob and all saved distances will be erased.

Warning!!!!

The distance values in memory cannot be recovered once erased. All saved values will be reset to zero.

R_x/T_X Notes

When using the remote display, it is important that the memory locations on both units match. The consoles check the memory location pointers when first powered up and will display the following alert if they do not match:

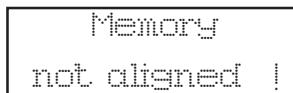

Simply erase the memory on both consoles to align memory.

Setup

Perform Distance Calibration



Drive Dist. Cal 1?
11761 >NO

Information line

Current setup value. Rotating knob when digit is underlined will increase and decrease number. Pressing in and releasing knob will select next digit to the left.

To change data, rotate the data selector knob until the display reads YES, then press in and release the data selector knob. To select next parameter, rotate data selector knob until display reads NO, press in and release knob.

This screen enables the console to perform a field calibration of the distance sensor. *(In software versions 3.9 and higher, two calibration numbers can be programmed.)* A distance of 300 feet needs to be measured and identified with flags or objects that can be seen from the operators seat.

To start the distance calibration, rotate the data selector knob to the left or right. When the word ">YES" is displayed, press in and release the data selector knob and the computer will display the screen below:



Enter to Start

Press Knob to
signal Start Flag

At this time, move the sled to the start of 300 feet, press in on and release the data selector knob, the screen below will appear and the numbers on the display will start counting up when the sled is moved.

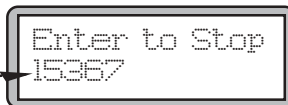

Enter to Stop
15367

Pulses counted

Press Knob to
signal end of run

When the sled is at the finish flag, press and release the data selector knob. This will indicate to the computer that the required distance has been driven. After the data selector knob is pressed and released the following screen will appear if the number is valid.



Drive Dist. Cal 1?
15682 >NO

If using a 2-speed differential, the second number can be calibrated using the 2nd speed of the differential. If using a single speed differential then ignore the setup for calibration 2.

Setup

Manually Edit Distance Calibration

Information line



```
Edit Dist, Cal7
15682 Edit>NO
```

Current calibration value. Rotating the data selector knob will increase or decrease the number. Pressing in and releasing data selector knob will select the next digit.

To change data, rotate the data selector knob until the display reads YES, then press in and release the data selector knob. To select next parameter, rotate data selector knob until display reads NO, press in and release knob.

This screen allows the distance calibration numbers to be changed manually. In most applications, performing the track calibration is adequate and the number should not have to be changed. This number informs the computer of the number of pulses transmitted by the speed sensor when driven a 300 foot distance.

To change the distance calibration number, rotate the data selector knob to the left or right and the words in the lower right corner will alternate between ">YES" & ">NO".

When the word ">YES" is displayed and the data selector knob is pressed and released, the computer enters allows the calibration number to be manually entered.

To change the number, rotate the data selector knob and the underlined number will increase or decrease. Pressing in and releasing the data selector knob will advance the cursor to the next digit on the left. When the last digit on the left is selected, pressing and releasing the knob again will let you save the entered value or exit the selected screen.

Warning!!! The minimum number that the computer will accept when driving the 300 feet is 3600. The maximum number is 25000. Any number not in this range is not recommended.

NOTE*A value of 3600 would enable the M3 to have a resolution of 1" increments when recording distance. Any number less than "7200" is not recommended for competitive pulling events.**

Repeat the above procedure to manually edit the second calibration number.

Setup

Auto Switch Cal

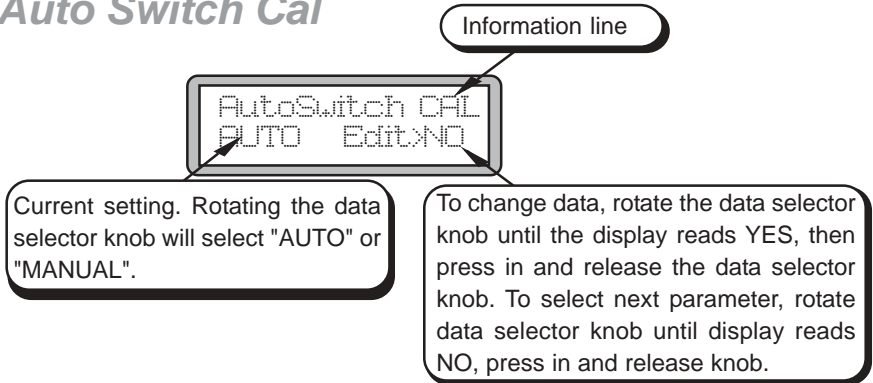

This screen allows the dual calibration numbers to be changed by manually selecting from the "RUN Screen" or automatically by using an external switch or relay.

Manual - When in this mode the calibration numbers can be selected from the "Run Mode". This method is not recommended due to the possibility of forgetting to change numbers after switching gears in the differential.

AUTO - When in this mode an external switch or relay can be used to change the calibration numbers. When in this mode it is not possible to change the calibration numbers manually from the run screen.

NOTE: All 2008 models have a 2 wire lead in the harness to connect to your relay contacts or limit switch. Simply connect the two wires together to select calibration number 2 and open the connection to select calibration number 1. If your unit is a pre 2008 model, your wiring harness and console can be sent in for the modification.

Pin numbers 35 & 36 in the 37 pin connector are used for the external 2-speed switch option

WARNING Do not apply battery voltage to these wires or possible damage to the monitor will occur.

Setup

Setting "Mile Per Hour Limit" Alarm



Current alarm value. Rotating knob when selected will increase and decrease numbers. Pressing in on data selector knob will select the next digit to the left.

To change data, rotate the data selector knob until the display reads >YES, then press in and release the data selector knob. To select next parameter, rotate data selector knob until display reads NO, press in and release data selector knob.

In pulling events such as antique tractor pulls where a maximum speed must be honored, the system comes standard with an external relay that will operate a load of up to 20 amps.

To set the "MPH Alarm", the operator enters the speed at which the alarm becomes active (99.9 mph maximum). *The console will close the set of contacts on the external relay when the actual MPH reading equals or exceeds the value entered in this screen.* The Sled Monitor has 4 alarm points that can be programmed. The four alarms can then be selected from the run screen. The alarm feature can also be turned off in the "run mode" by selecting "Off" in the alarm selection screen.

R_x/T_x Notes

The sled monitor sends distance and speed information to the remote display during the pull. Depending on the signal strength and obstacles in the radio path (trees, buildings, etc.) the remote display may lag behind a few readings especially on speed. (The distance data is given highest priority) The system is designed so that when the sled console sends the distance and maximum speed data to the remote display at the end of the pull, the information is checked for accuracy and an acknowledgment is sent from the remote display back to the sled monitor. In other words it is not possible for the remote display to receive and acknowledge invalid information.

Setup

Display units

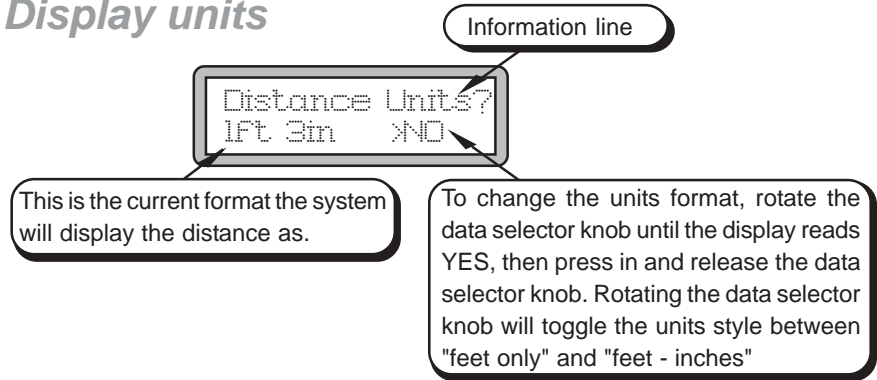

This setup feature instructs the display to readout in feet and inches or feet only. (see table below for examples)

Feet only	Feet and inches
128.45 ft	128 ft 5.42 in
87.21 ft	87 ft 2.52 in
289.89 ft	289 ft 10.68 in

Rx/Tx Notes

If using the radio remote unit, be sure to set the units the same as the sled monitor.

Relay Test

This feature allows the operator to test the external relays, lights and wiring for proper operation.

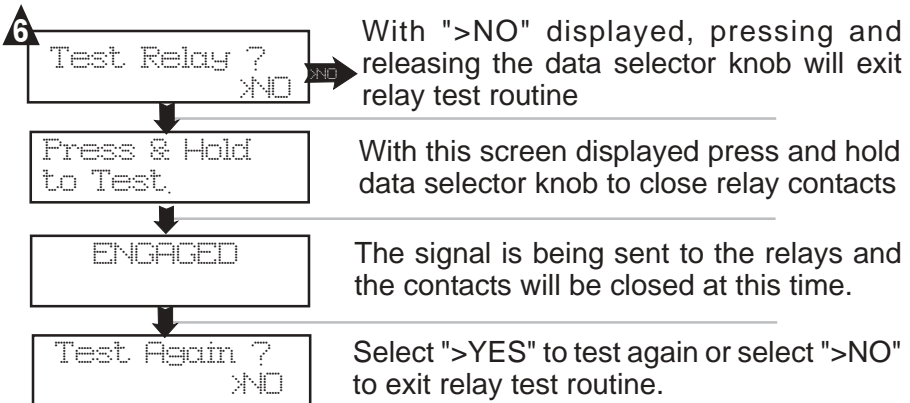

Setup

Enable radio link to remote display

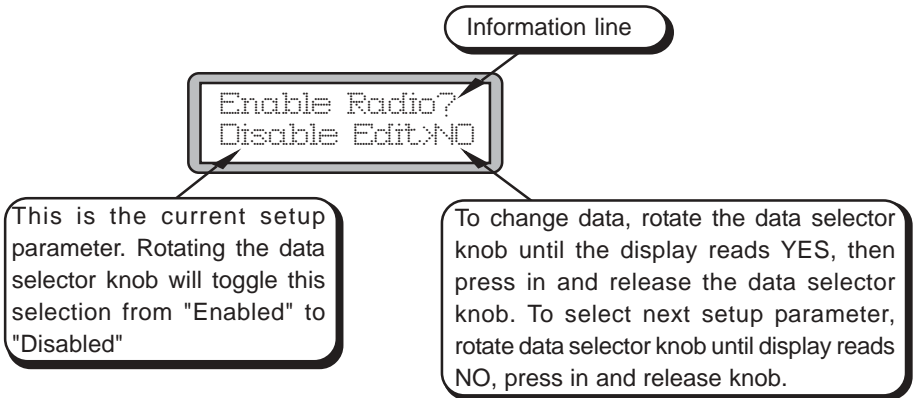

If your system is equipped with the radio circuit (*A 4 inch antenna will be attached to the console*), this screen enables the radio link feature.

To enable the radio board software, rotate the data selector knob to the left or right and the words in the lower right corner will alternate between ">YES" & "> NO".

When the word ">YES" is displayed and the data selector knob is pressed and released, rotating the data selector knob allows the radio link feature to be "Enabled" or "Disabled".

Make the appropriate selection, press and release the data selector knob.

R_x/T_x Notes

If the radio option is enabled and there are no radio boards, the software will search indefinitely for a valid radio link. If this happens, turn the console off, enter the setup mode and disable the radio option.

If the radio option is set to "Disabled", this will complete the setup routine and the console will return to the "Measuring" mode. If the radio option was set to "Enabled" then the setup parameters on the following pages will need to be configured.

Setup

Set as Receiver or Transmitter.

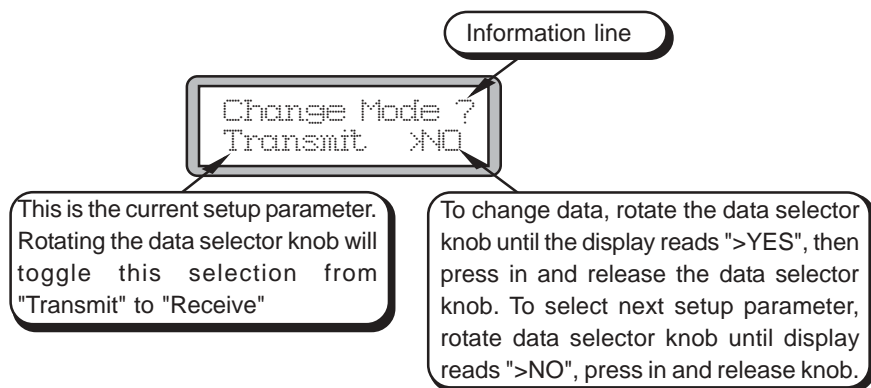

If the radio option was enabled in the system setup, this screen will appear allowing the operator to configure the console as the transmitter (sled monitor) or receiver (remote display).

The consoles are equipped with a radio system that can receive and transmit. This allows either console to be used as the sled monitor or the remote display.

NOTE No damage will occur to the system if both units are set for transmitter or both units are set as receivers, although the system will not work as desired.

Animated Icon Indicators

When the receiver and transmitter console are in the "Ready" screen, an animated icon will indicate the radio link is functioning. If the animated icon does not appear or is not moving, the radio link is not communicating.

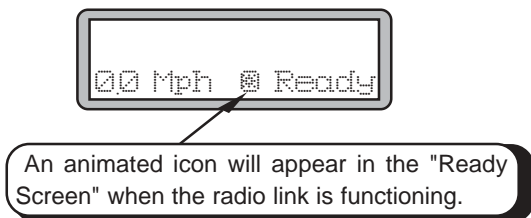

Note

The "Ready Screen" is the only time animated icon will appear

Setup

Enter communication channel



Change Channel
Channel 2 >NO

Information line

This is the current channel. Rotating the data selector knob will select different channels (1-127) to transmit on.

To change data, rotate the data selector knob until the display reads YES, then press in and release the data selector knob. To select next setup parameter, rotate data selector knob until display reads NO, press in and release knob.

If the radio option was enabled in the system setup, this screen will appear allowing the operator to set the radio channel that the radio boards will communicate with. This feature allows multiple sled monitor systems set to different channels to be used within the same area.

NOTE!!

When setting this value, the sled console and the remote console must be set on the same channel number. If the channel numbers do not match, the two consoles will not be able to establish communication and the following screens will appear on the transmitter console. The number displayed will be number that was programmed when setting the channel number.



Rx/Tx Channel
Z

Rotating the data selector knob will select different channels to transmit on. Available channels are 1-127

Set the communication channel to any channel between 1 and 127. Make sure the remote console and sled console are set to the same channel or the consoles will not communicate with each other. After selecting desired channel press and release the data selector knob to exit this setup feature.

Setup

Enter frequency band



Change Band ?
Band # 62 >NO

Information line

This is the current frequency band. Rotating the data selector knob will select different frequency bands (0-63) to transmit on.

To change data, rotate the data selector knob until the display reads YES, then press in and release the data selector knob. To select next setup parameter, rotate data selector knob until display reads NO, press in and release knob.

In some locations it may be necessary to change the frequency band that the radios communicate on. Two-way radios and communication equipment that is close in frequency to the sled monitor system setup will sometimes cause intermittent operation of the system

NOTE!!

When setting this value, the sled console and the remote console must be set on the frequency band number. If the frequency band numbers do not match, the two consoles will not be able to establish communication



Band # 2

Rotating the data selector knob will select different frequency bands channels to transmit on. Available bands are 0-63

Set the frequency band to any band between 0 and 63. Make sure the remote console and sled console are set to the same channel or the consoles will not communicate with each other. After selecting desired band press and release the data selector knob to exit this setup feature.

Setup

Signal Strength



Listen For other
Radios >NO?

After setting the communication channel and establishing a radio link, the radio signal strength of the sled console can be checked with the built in signal strength meter on the remote console. When the above screen appears, select ">YES" and press in and release the data selector knob.



Waiting

While the remote console is searching for the radio signal from the sled console, the screen shown above will appear. Normally this screen will appear only for a brief moment before the screen below appears. If the system stays on this screen be sure the sled console is turned on, set for transmit and the channel number is the same as the remote console.

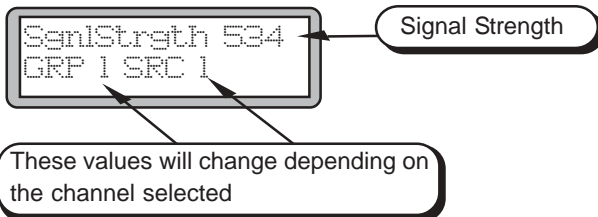

When the receiver and transmitter have established communication, the remote console will display the signal strength of the radio signal.

(To exit the signal strength routine, press and release the data selector knob)

The radio link has been tested for consistent reliable operation in distances over 500 feet outdoors with line of sight conditions. The system performs best with a signal strength of at least 400.

1. Although the radio link will communicate through structures, the best results are obtained in open area where the antennas have line of sight.
2. Locate the units so that the metal cab of the sled or metal building of judges stand does not block the radio signal.

This completes the Setup Routine!

Reference Section

Wiring Diagrams

Console Connector

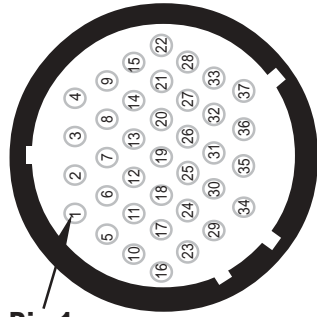

Pin 1

37-Pin Connector Wiring	
26	Relay ground
27	Relay ground
28	Relay out (MPH Alarm)
29	Relay out (Staging)
35	Ground for limit switch option
35	Limit switch signal

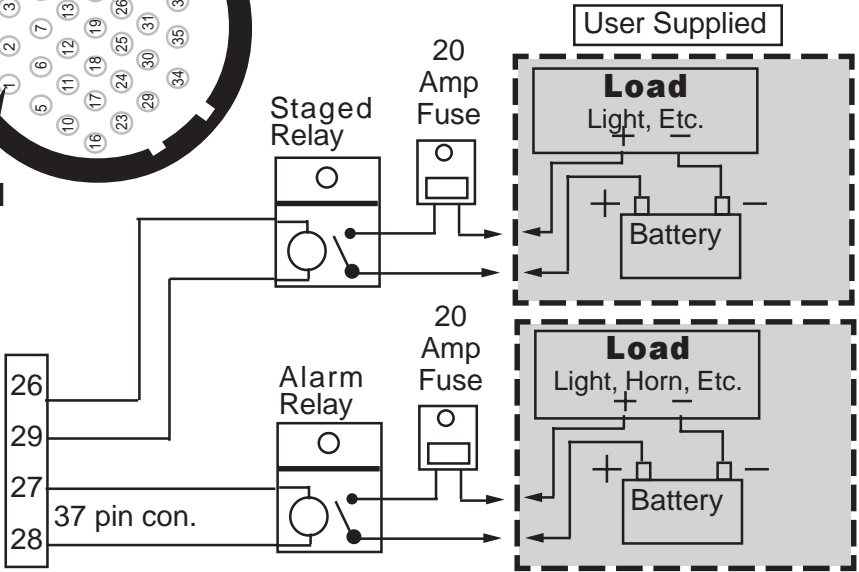

Distance Connector

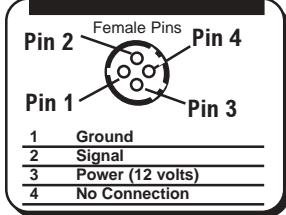

Power Connector

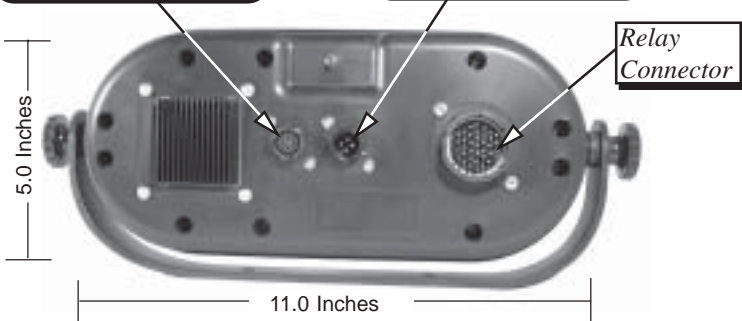
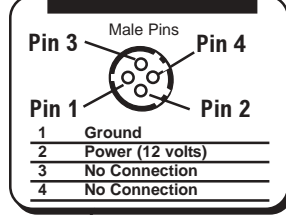

Sled Console Operation

Turn power switch on

Power-up Screens

1 Software Version
3.90

This is the current level of software loaded into the console.

2 Resolution of
0.31 inches

This is the value of each pulse from the distance sensor.

3 6 Pulls Stored
in Memory

This is the current number of pulls saved in the nonvolatile memory.

4 Alarm Set
at 40 MPH

This is the current trip point for the relay when using the MPH alarm.

5 Receive Mode

Displays "Receive Mode" or "Transmit Mode", if the console has been set up for the radio link option

System advances to the Measuring Mode Screen

M3 Measuring Mode Screens

1 00 Mph Ready?

This screen allows the sled to be moved without recording distance. (Speed will be displayed)

Press to knob to advance

2 0ft 000in
00 Mph STAGED

This screen indicates that the system is ready to start recording distance. The console will begin displaying distance when a distance pulse is received.

Advances when sled moves

3 123ft 367 in
32 Mph

The unit will start recording distance when motion is sensed.

Caution! Pressing the Enter button during recording will cause distance to reset to zero.

Advances when sled stops

4 210ft 1032in
48 Mph Save ?

The system stops recording 5 seconds* after motion has stopped.

*If less than 1 foot has been measured the console will not time out. If between 1 ft and 75 ft the console will time out after 30 seconds. If over 75 feet the console will time-out in 5 seconds when at 0.0 speed.

Press to knob to advance

5 210ft 1032in
48 Mph 23 Saved

This screen appears after a save is performed. The number of "saves" in memory are displayed.

(advances after value is saved)

Sled Console Operation

Data Selections

The console has several options to recall and view data. The screens and explanations are listed below. Pressing the data selector knob will advance the console to the screen shown on the right.

Displays speed without recording distance.

1
00 Mph Ready?

Enter

System is ready to measure distance and the staging relay closes

0Ft 000in
00 Mph STAGED

(rotate knob to advance)

Allows the distance measurements to be saved to nonvolatile memory.

2
67Ft 3.45in
85 Mph Save ?

Enter

Distance & Maximum Speed are saved. The total number saved pulls is displayed. (Up to 100 pulls)

67Ft 3.45in
85 Mph 12 Saved

Returns to Screen 1

(rotate knob to advance)

Allows the distance measurements to be discarded and not saved to memory.

3
67Ft 3.45in
85 Mph Discard?

Enter

Current reading is erased and not saved to memory. All saved locations will remain intact

85 Mph ERASED

Returns to Screen 1

(rotate knob to advance)

Select Alarm 1, Alarm 2 or turn off alarm function

4
35 Mph Alarm 1

Enter

Rotating knob will select Alarm 1, Alarm 2, or disable alarm.

Alarm 1 is ON
35 Mph Alarm 1

Returns to Screen 1

(rotate knob to advance)

Allows up to 100 saved distances to be displayed and reviewed.

5
00 Mph Recall?

Enter

Displays all saved distances by rotating data selector knob. Up to 100 pulls can be recalled.

123Ft 2.73in
83 Mph Pull 12

(rotate knob to advance)

Displays of the longest distance and pull number saved in memory.

6
00 Mph Max Pull

Enter

Length of the longest pull in memory and the pull number are displayed.

298Ft 5.73in
12.4 Mph Pull 32

(rotate knob to advance)

Remote Console Operation

Setup

Enter the setup mode (power off unit, hold data selector knob in, power on unit, release data selector knob).

- 1 Erase Memory?
 >NO → Any time the memory in one of the consoles (sled or remote) is reset, the other console must be reset to keep the memory files aligned.
- 2 Drive Dist. Cal?
 11761 Edit>NO → A field calibration is not necessary on the remote display.
- 3 Edit Dist. Cal?
 11761 Edit>NO → The calibration number from the sled console needs to be entered into the remote console in this screen.
- 4 Edit Mph Alarm?
 50 Edit>NO → It is recommended that this feature be set to 0.0 (disabled) on the remote display.
- 5 Distance Units
 1.5 Ft Edit>NO → Distance units can be set in either mode on the remote console (It does not need to match the sled console set up)
- 6 Test Relay ?
 >NO → The relays can be tested, although it is not necessary on the remote console.
- 7 5th Wheel Option
 OFF Edit>NO → This feature is used when setting up sled console. Feature set to "OFF" in remote setup.
- 8 Enable Radio ?
 Disabled >NO → This screen must say "Enabled" on the bottom line for the radio link to operate.
- 9 Disable Radio ?
 Enabled >NO → This is what the remote screen looks like when the radio option is turned on.
- 10 Change Mode ?
 Receive >NO → This screen must be set to "Receive" on the remote console and "Transmit" on the sled console.
- 11 Change Channel?
 Channel 2 >NO → The channel number of the remote console must be the same as the channel number on the sled console.
- 12 Change Band?
 Band # 2 >NO → The Band is the frequency band the radios will communicate on.
- 13 Listen for Other
 Radios ? >NO → This feature allows the signal strength between radios to be checked at different distances.

Enter run mode

Remote Console Operation

Establishing radio contact

After the radio option has been enabled on both consoles and the channels are set to the same number, the consoles can be powered up.

When the sled console is powered up it will go through the power-on screens and will then send a radio signal out searching for the remote console.

The following sled console screens will appear:

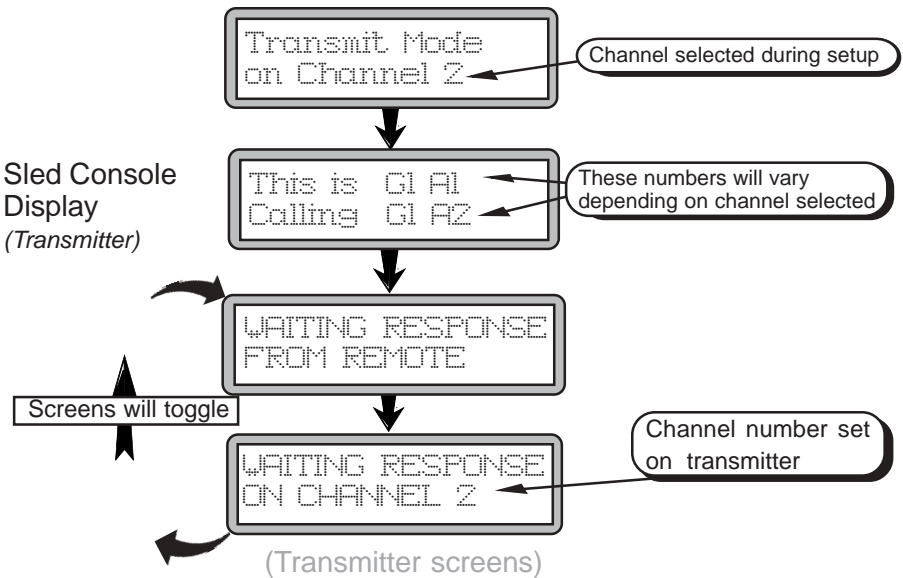

Note! The above two screens will continue to display until the radio link is established or the unit is powered off.

Animated Icon

Once a radio link is established the remote console and sled console will both have an animated icon that indicates they are receiving and transmitting a radio signal. The animated icon will be visible only when in the ready mode. This assures both the sled operator and the remote display operator that the communication link operating properly.

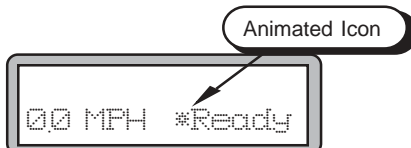

Remote Console Operation

Checking Signal Strength

The remote console (Receiver) has a built in signal strength meter that can be used to check the signal level being transmitted from the sled console (Transmitter). It is always a good idea to check the signal level at both ends of the track to ensure trouble free operation.

Procedure to check the signal strength:

1. Turn both consoles off.
2. Power up the remote console while holding the data selector knob in. When the words "SETUP MODE" appear on the screen release the data selector knob.
3. Repeatedly press and release the data selector knob until the display reads "Listen for other radios?"



Listen for other
Radios ?

4. Turn the data selector knob until the display reads ">Yes" in the lower right corner.
5. Press and release the data selector knob and the following screen will appear until a radio link is established. (normally less than 1 second)



Waiting ..

6. Once the radio link is established the screen below will appear that indicates the strength of the received signal.



SenStrength 434
GRP 1 SRC 1

Signal Strength

These values will vary depending
on the channel that was selected

Note! For optimum results a signal strength of 400 or higher is recommended. The radio link will operate below a signal strength of 400, but the best performance is achieved above 400.

7. Press and release the data selector knob to exit signal strength test.

Remote Console Operation

Operation

When the consoles are first turned on and the radio link is established, the sled console will check the internal memory of the remote display to make sure the memory locations are starting from the same point. (i.e. If the sled console is going to save to memory location 87 next then the remote console needs to save to memory location 87 also.)

If the memory locations are not the same the sled console will display the following warning.

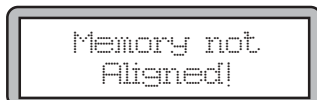

If this warning should appear on the sled console, enter the setup mode and erase the memory of **both consoles** to realign the memory. (Note.... This will not change any setup information)

Sequence of events during a pull

With both units on, in the ready mode, when the sled operator presses the data selector knob to "Stage" the monitor, the remote console will also display the word "Staged" in the lower right corner.

When the sled begins to move the distance reading will appear on the top line of the display and the speed of the sled will appear in the lower left side of the display.

When the sled stops moving both consoles will display "Save?" on the display.

IMPORTANT!!! DO NOT press the data selector knob on the **remote display** to save pull values. The memory sections of the two consoles will be out of alignment. The sled operator saves the value to both consoles when the sled monitor value is saved.

When the **sled operator** presses the data selector knob to save the pull information, the data will also be saved to the remote display and then both consoles will return to the "Ready" screen.

The information in the remote console can be reviewed anytime a distance reading is not displayed on the top line. Be sure to place remote console in "Ready" mode before next pull begins.

NOTE! This system is designed so that the sled operator will always transmit the pull information to the remote display when the save function is performed.

Common Questions

The following is a list of common questions:

Q. Why does the console not respond to the data selector knob and appears to be "locked up".

A. The console needs to have at least 10.5 volts for reliable operation. The console will appear to be on but will not function reliable below 10.5 volts.

Q. Why does the console display "Memory not Aligned" when turned on?

A. This occurs when the number of saved values of the remote console and sled console do not match. Enter the setup mode and clear the memory of both units to turn off this warning.

Q. I made a pull and the console showed speed but did not display a distance reading.

A. This will occur if the sled operator did not "stage" the system before the pull. At the end of the pull, if the word "Save?" does not appear then the sled console was not staged.

Q. Can I unplug the console from power and not lose my setup information and saved pulls?

A. Most definitely! The sled system has special circuitry that retains all setup information and pull information without the need for power.

Q. I have a system that does not have the radio link, can it be upgraded to the radio linked system?

A. Yes, contact Agri-Tronix about a competitive upgrade to your system.

Q. Can more than one Agri-Tronix sled system be used at the same event at the same time.

A. As long as the different systems are set to a different channel, 128 systems could be used at the same time during the same event.

Common Questions

Q. Can I manually enter the calibration number if I know how far the sled was actually moved?

A. Yes! The new calibration number is calculated by dividing the value on the sled monitor display by the actual measured distance the sled was moved and then multiply that answer by the current calibration number.

$$\text{New cal \#} = \frac{\text{sled monitor value}}{\text{actual distance value}} \times \text{current cal. number}$$

Q. What is the accuracy of the sled monitor system?

A. The accuracy depends on the distance sensor used. After calibrating the system the resolution of the distance sensor will be displayed during the powerup screens.

Q. What is the staging relay used for?

A. The staging relay is provided to prevent the green light from coming on if the monitor has not been "staged". This will prevent a pull from being made when the distance recording feature has not been enabled (staged).

Q. Can the remote display be used on the sled?

A. Yes, both consoles are identical and the remote display provides an excellent back up in the event the console on the sled should be damaged or fail.

Q. Why does the sled monitor display "WAITING RESPONSE FROM REMOTE" "ON CHANNEL (1-127)"?

A. This occurs if the sled monitor (transmitter) does not receive acknowledgment from the remote display (receiver). Check the remote to be sure it is powered on, has been programmed to "Receive" mode, and is set to the same channel as the transmitter.

Q. How many teeth do I need on the sprocket ?

A. On most drive shaft applications a 60-tooth sprocket similar to those used on a go-cart will provide a resolution of .25 to .4 inches. Since all sleds are built different, there is not a given number for this question.

Warranty

Agri-Tronix Corporation warrants to the original purchaser that the console and wiring harness, will be free of defects in workmanship and materials for a period of two years from the date of delivery. During the warranty period, Agri-Tronix Corporation will repair or replace, at its sole discretion, the defective hardware, free of charge for labor and parts. Purchaser must prepay shipping. Additionally, international purchasers must prepay any and all customs fees, taxes and added taxes. This warranty will not be extended by any additional purchases or upgrades.

All components not manufactured by Agri-Tronix Corporation will be covered under the product manufactures warranty.

Excluded from this warranty is any damage caused during shipment except the shipment to the original purchaser and any damage caused by: impacts, fluids, fire, flood, wind, earthquake, lightning or similar disaster; unauthorized modifications, attachments or peripherals; improper use, environment, installation or electrical supply; improper maintenance; any other misuse, abuse, or mishandling.

Agri-Tronix's sole liability, under this warranty, for failure to repair the hardware system after a reasonable number of attempts is limited to replacement or, at Agri-Tronix's sole discretion, refund of the original purchase price.

Agri-Tronix shall, under no circumstances, be liable for any other damages, including but not limited to special, incidental, consequential and other similar claims whether based upon breach of contract, breach of warranty, negligence, absolute or strict liability, or any other similar theories. Damages excluded include but not limited to loss of profit, loss of revenue, loss of use of the system, loss of use of related equipment, cost of substitute or replacement equipment, "down time", purchaser's time, injury to property, and all claims of third parties.