



SW600 Operators Manual



Ft. Atkinson, Wisconsin USA



Panningen, The Netherlands

www.digi-star.com

TABLE OF CONTENTS

CHARGING BATTERY OR WELDING	3
INDICATOR OVERVIEW	4
BOTTOM PANEL	5
OPERATION	6
TURNING ON THE SCALE	6
ZERO BALANCING	6
WEIGHING ANIMALS	6
SELF TEST	7
OPTIONAL SETTINGS	7
CHANGE SETUP FOR LOAD CELLS	7
DETERMINING THE NEW CAL NUMBERS	8
CHANGE OPTIONS (USING LONG FORM SETUP).....	9
WEIGH METHODS	12
GENERAL WEIGH METHOD	12
SLOW WEIGH METHOD	12
FAST WEIGH METHOD	12
LOCK-ON WEIGH METHOD	12
WEIGHING ERRORS	13
STOCKWEIGH LOAD CELLS	14
STOCKWEIGH LOAD CELL SPECIFICATIONS	14
LOAD CELL DIMENSIONS	15
SCOREBOARD METHODS	17
PRINT FORMATS	18
TROUBLESHOOTING GUIDE.....	20
INSTALLATION	23
INDICATOR MOUNTING.....	23
OPTIONAL RAM MOUNTING	23
LOAD CELL CONNECTION	24



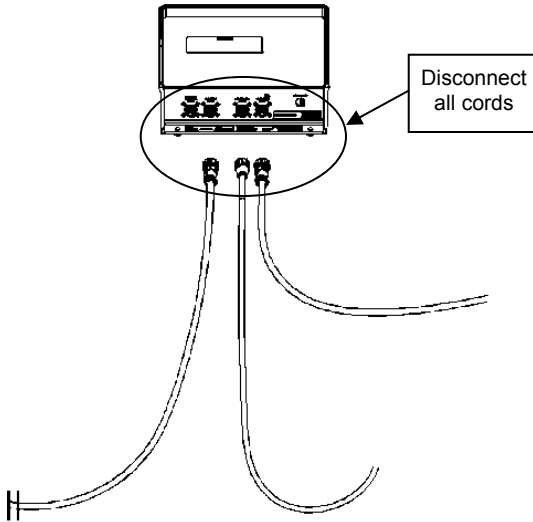

CHARGING BATTERY OR WELDING

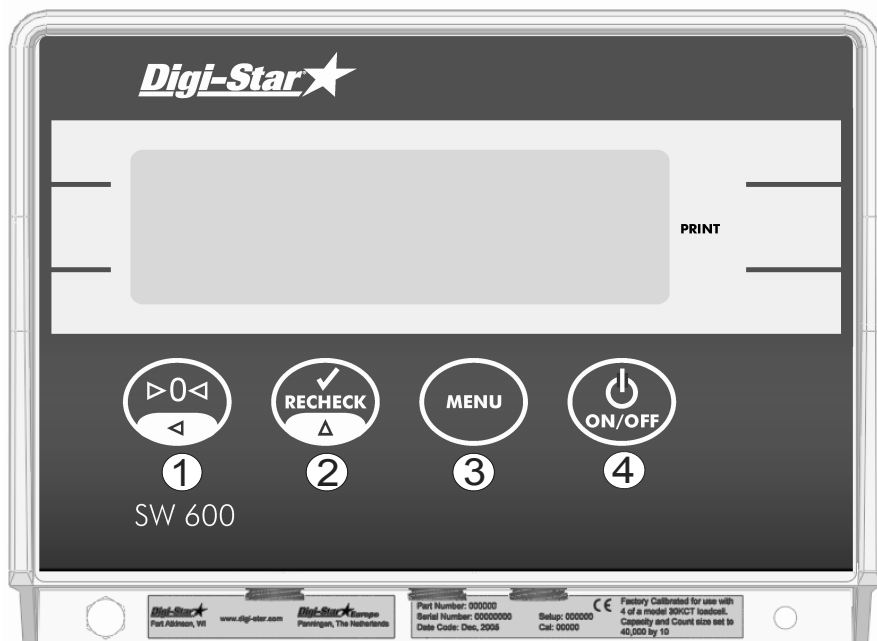

Important: Disconnect all indicator leads before charging battery or welding equipment. Damage may occur to indicator and load cells.

INDICATOR OVERVIEW

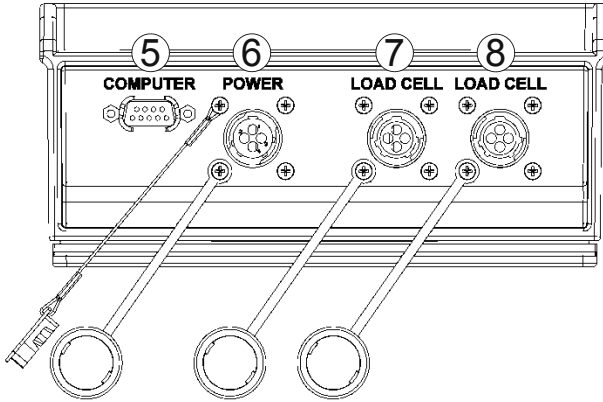

- ①  - press and hold to zero balance.
- ②  - reweigh if scale is locked on.
- ③  - press and hold for setup menu.
- ④  - turns indicator on/off.

BOTTOM PANEL

- ⑤ Serial/Printer – Port used to communicate with computer and other digital input/output devices such as a printer.
- ⑥ Power – Port for Power Cord.
- ⑦ Load Cell – Port for load cell cord.
- ⑧ Load Cell – Port for load cell cord.

OPERATION

TURNING ON THE SCALE



1. Press .

ZERO BALANCING

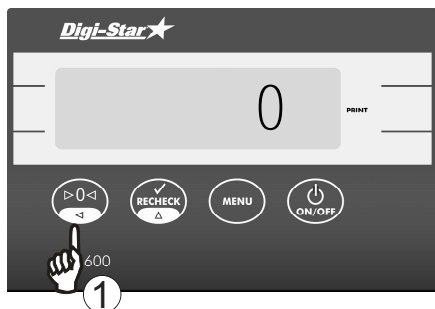



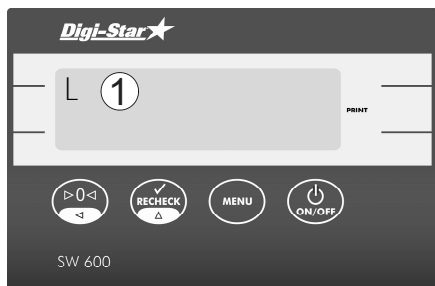

1. Press and hold  to zero balance.

WEIGHING ANIMALS

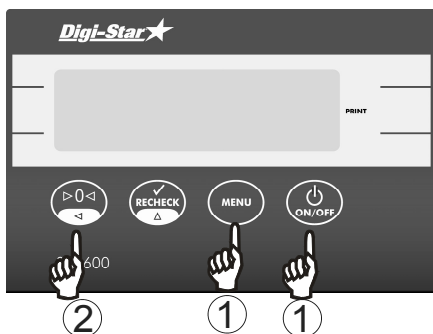

1. Place animal on platform.
Indicator "Locks On" animal's weight, "L" appears in upper left of display.
2. Release animal.





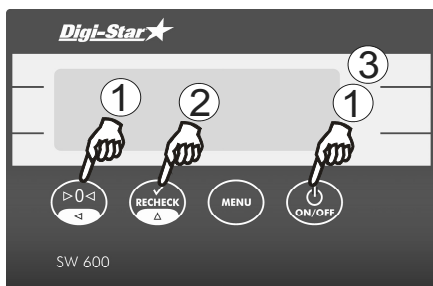

1. Press  and within three seconds press  to start self test.
2. Press  to exit test (except during key test).

OPTIONAL SETTINGS

CHANGE SETUP FOR LOAD CELLS.



1. Press and hold  and  for long form setup menu.
2. Press  to advance through selections
3. Press  to set.

3300LB	StockWeigh 3300 (pounds)
6600LB	StockWeigh 6600 (pounds)
10K LB	StockWeigh 10000 (pounds)
14K LB	StockWeigh 14000 (pounds)
3300KG	StockWeigh 3300 (kilograms)
6600KG	StockWeigh 6600 (kilograms)
10K KG	StockWeigh 10000 (kilograms)
14K KG	StockWeigh 14000 (kilograms)
Custom	Any other load cell.

DETERMINING THE NEW CAL NUMBERS

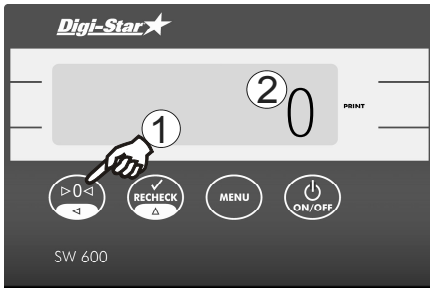





1. Press and hold  to zero balance the scale.
2. Place a known weight on the scale (Example: 1000 LB test weight).

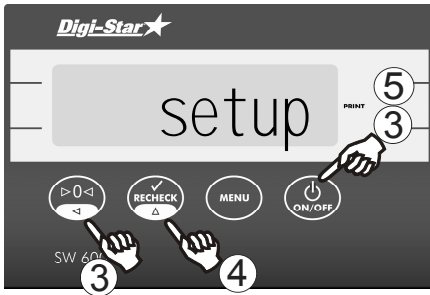



Perform the following calculation to find the new calibration number:

$$\frac{\text{Known Weight}}{\text{Displayed Weight}} \times \text{Existing Calibration Number} = \text{Accurate Calibration Number}$$

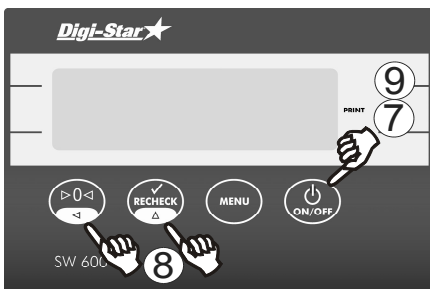





3. Press and hold  and  to enter setup menu.
4. Press  to select Custom (see page 7).
5. Press . Indicator will display SETUP followed by the setup number.





6. Setup number does not change.
7. Press  to advance to "Cal".
8. Enter the new CAL # by pressing  to change the value of "flashing" digit and  to select which digit of display is flashing.
9. Press  to store new calibration number.

CHANGE OPTIONS (USING LONG FORM SETUP)

To modify options in following chart:

1. Press and hold .
2. Press  to change setting.
3. Press  to save setting and advance to next menu item.
4. Press  to return to weighing mode.

Setting/ Display	Options (Bold = Default)	Description
MENU 1		
Language LANGAG	ENGLISH NEDERL FRANCS DEUTSH ITAL PORT ESPAN DANSK MAGYAR VESTA	Select from list English Dutch French German Italian Portuguese Spanish Danish Hungarian Spanish
Zero Tracking ZTRACK	1-99 or OFF	Adjusts to zero for build-up of snow, mud and manure, (when weighing animals). Weight value can be set from 1 to 99 lbs/kgs or OFF (00).
Weigh Method W MTHD	1, 2, 3, 4	Select weigh method. See page 12.
Lock-On LOCKON	1-7 , 8, 9	Use the lowest setting that still allows the system to lock on consistently. A low value allows the system to be more sensitive to animal motion. A high value allows the scale to lock on faster.
Lock-N-Hold LKNHLD	On/OFF	Weight is held until next animal is weighed.

Setting/ Display	Options (Bold = Default)	Description
Auto Off AUTOFF	15, 30, 45, 60, OFF	Indicator automatically shut OFF after specified time of inactivity.
Lock-On Store (LSTORE)	OFF AUTOWT MANPRT	Sends data to computer port only when TAREAP or APRINT are set to "ON". Automatic Weight Sends time, date and weight data to computer port when the scale "Locks-On" or when the animal steps off platform. -Sends time, date and weight data to the computer port when operator presses  .
Lock-On Store (LSTORE)	AUTOPRT MANWT	Sends Time, Date and Weight data to the computer port when the scale locks-on or when the animal steps off the platform. -Sends time, date and weight data to the computer port when operator presses  .
Lock-On-Store Send (LSEND)	ON/OFF	LSEND is for LSTORE automatic modes and has no effect in manual modes. If set to "OFF", data is sent when animal steps off the platform. If set to "ON", data is sent as soon as the scale locks-on. If set to "ON", press  to recheck the weight and send new data to computer port.

Setting/ Display	Options (Bold = Default)	Description
One Line Print 1LPRI NT	On/OFF	ON formats printer output data on one line. OFF formats printer output data in two lines.
Scoreboard Mode SCOREM	1,2,3,4,5,6,	Methods to continuously output display data to a scoreboard via the com port. See page 17.
Auto Print APRI NT	On/OFF	Weight value printed automatically.
Com In Com In	DOWNLD, EZ CMD, EZ2CMD	Com port interface selections DOWNLD for Data Down Loader, EZ CMD = Original EZ Commands, EZ2CMD = EZII Escape Commands.
Print Format PRTFMT	AUTO, WTONLY, DOWNLD, DT+TM, ID+TM, IDWTTM, ANIMAL	See page 18.
Com 1 Delay C1 DLY	OFF, .10, .25, .50, .75, 1-5	Choose the number of seconds the printer will delay before advancing to the next print line.
Com 2 Delay C2 DLY	Not Used.	
Display Count COUNT	.01,.02,.05,1,2,5,1, 2,5,10,20, 50,100	Indicator display count. If the counts are too small, the reading will show more instability.
Auto-Range ARANGE	ON/off	Increases display count size for weights over 300 and again at 600 lbs/kgs.
Display Unit LB-KG	LB/kg	Display units.
Capacity CAP	4000	Enter MAXIMUM weight measurable on scale.

WEIGH METHODS

Select weigh method #4 for animal weighing. When weighing dead loads, you can still use the Lock-On Weigh method but you may wish to use one of the other methods listed below.

GENERAL WEIGH METHOD

All-purpose weigh method for weighing dead loads. It is used for most applications.

SLOW WEIGH METHOD

Attempts to provide higher accuracy by filtering many weight samples over a longer period. Use for weighing dead loads.

FAST WEIGH METHOD

The Fast weigh method is more sensitive to weight changes than the other weigh methods. When a weight changes quickly, the Fast method tries to determine the new weight as quickly as possible. This method is for weighing dead loads.

LOCK-ON WEIGH METHOD

Weighs active animals and displays stable accurate weight. Lock-On sensitivity adjusted using “LOCKON” menu.

- Once actual weight is displayed, scale “Locks-On” to weight.
- Weight is displayed stable, even if motion never stops.
- Small ‘L’ appears on left side of display indicating weight “Locked-On.”
- Animal’s weight must be greater than 0.67% of scales “capacity” weight before system can “Lock-On.”

Note: Customers should use a weight value for Zero Tracking (ZTRACK) that is less than 0.67% of capacity.

To break lock, add or remove preset percentage of displayed weight. The default setting is 50%.

- The weight value that is used to “break the lock” and return to normal weighing can be selected by choosing a value from 01 to 99%. For example, if unlock is set to 10(%) and weight is locked at 1000, display will “unlock” and return to normal weighing at 900, once 10% (100) is removed.
- “Locked-On” weight can be “rechecked”, pressing  breaks “lock” and scale recalculates weight.

WEIGHING ERRORS

OVRCAP **Over Capacity Limit**

The display shows the message "OVRCAP" if the weight on scale system exceeds capacity limit.

+RANGE **Over Range**

The display shows message "+RANGE" if weight on the scale system is less than the maximum weight measurable by scale system.

-RANGE **Under Range**

The display shows message "-RANGE" if the weight on the scale system is less than the minimum weight measurable by the scale system.

LO BAT **Low Battery Indication**

If the supply voltage drops below the (10.5 Volts), the message 'RECHARGE BATTERY – TURNING OFF' and "LO BAT" will periodically show on the display to alert the operator of the low battery condition.

Warning!



Disconnect the indicator power cord before jump-starting or fast charging a battery.

Disconnect all indicator leads before welding on equipment. Damage may occur to the indicator and load cells.

STOCKWEIGH LOAD CELLS

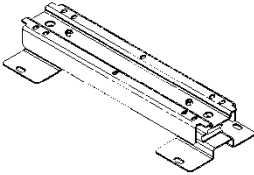

Load Cells with Connectors:

	Model 3300			Model 6600	
Length	16"	24"	33-1/2"	33 1/2"	44"
Part Number	148042	146769	400144	400058	400006

Load Cells without Connectors:

	Model 3300			Model 6600	
Length	16"	24"	33-1/2"	33 1/2"	44"
Part Number	403481	403482	403483	403484	403485

Model 14,000	
Part Number	400161

STOCKWEIGH LOAD CELL SPECIFICATIONS

<p>GROSS CAPACITY Model 3300: 3300 lbs. Maximum Model 6600: 6600 lbs. Maximum</p> <p>ACCURACY: ±1% and ±Display Increment</p> <p>OVERALL DIMENSIONS Model 3300: 3-3/4" H x 8-1/4" W x 16, 24 & 33-1/2" L Model 6600: 3-3/4" H x 8-1/4" W x 33-1/2 & 44" L</p> <p>Load Cell Cable Length: 14 Feet</p>	<p>RESOLUTION (FOR BOTH MODELS) Increment/Range 1 lbs or kgs 0-300 lbs or kgs 2 lbs or kgs 300-600 lbs or kgs 5 lbs or kgs ⇨ 600 lbs or kgs</p> <p>POWER REQUIREMENTS: 12-14 VDC @ approx 1 Amp</p> <p>AC TO DC CONVERTER 110 VAC to 13.8 VDC @ 1.2 Amps</p>
---	--

LOAD CELL DIMENSIONS

Model 3300

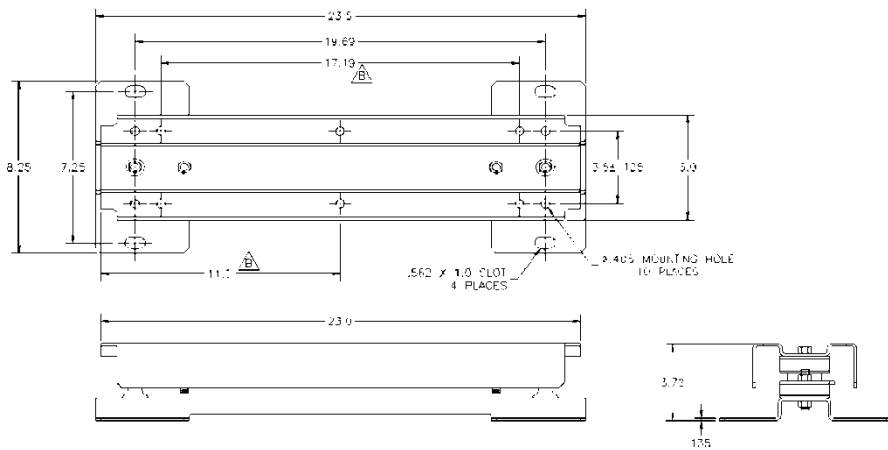

Model 6600

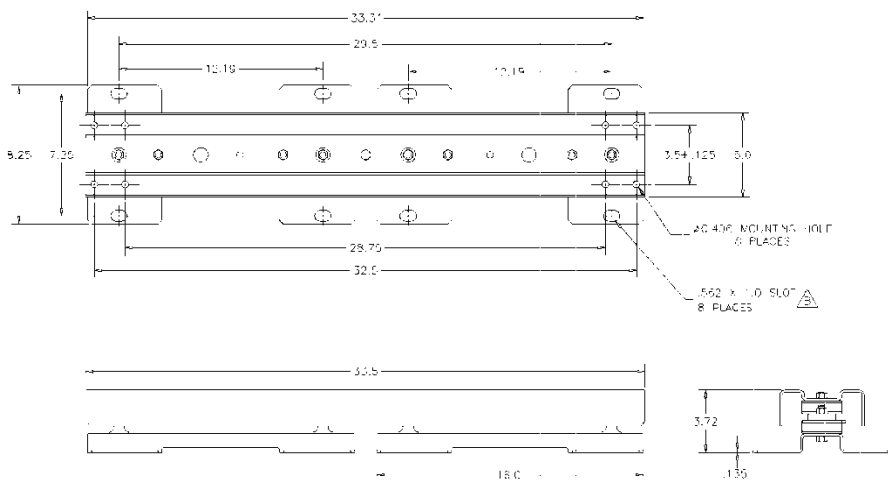

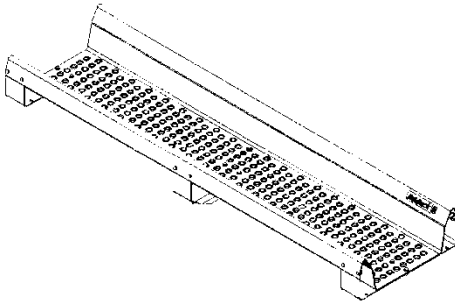

StockWeigh Alley Platform
PN 403360



120 Volt AC/12 Volt DC Power Converter
PN 403526

SCOREBOARD METHODS

Scoreboard methods 1 through 6 are used for the Stock Weigh 600. Many other scoreboard methods are available but are not used.

1. Transmit numeric display data once per second.
2. Transmit numeric display data two times per second.
3. Transmit numeric display data three times per second.
4. Transmit numeric display data at the A-D conversion rate.
5. Transmit numeric display data at the display rate.
6. Transmit numeric display data whenever there is a display weight change.

NOTES: When using SCOREM = 1, 2, 3, 4, 5 and 6 be sure to set LSTORE = OFF, TAREAP = OFF and APRINT = OFF to avoid corrupted data when transmitting scoreboard data and printing scale data.

With COM IN set to EZ2CMD the port configuration is: 9600 Baud, 1 start bit, 7 data bits, 1 even parity bit and 1 stop bit.

With COM IN set to EZCMD the port configuration is: 1200 Baud, 1 start bit, 7 data bits, 1 even parity bit and 1 stop bit.

PRINT FORMATS

PRTFMT is active when "LSTORE" is set to "OFF", "MANPRT" or "AUTPRT". Following is a detailed explanation of the print formats that are available on the StockWeigh 600. Some are Comma Separated Values (CSV) that make it easier to input scale data into PC Spreadsheet and Data Base programs.

NOTE: The appearance of the printouts may be affected by the option settings of 1L PRT, TIME F and DATE F.

- AUTO** If "LSTORE" is set to "MANPRT" or "AUTPRT" and "PRTFMT" is set to "AUTO", the standard EZ Indicator print format will be used.
Print example:
09MR04 10:15
880LB\$GR
- WTONLY** Includes weight, display unit, '\$' if unit is "locked on", weight tag (GR, M+, etc.).
Ends with a <CR>,<LF>. Print example:
635LB\$GR
- DOWNLD** This format is compatible with the original Downloader.
Includes weight, display unit, '\$' if unit is "locked on", weight tag (GR, M+, etc.) date and time.
- DT+TM** This CSV format includes weight, display unit, '\$' if unit is "locked on", weight tag (GR, M+, etc...) and date.
Ends with a <CR>,<LF>.
Print example:
"**610,LB, ,GR,13MR02,11:08**"
- ID+TM** This CSV format includes ID, weight, display unit, '\$' if unit is "locked on", weight tag (GR, M+, etc...) and time.
Ends with a <CR>,<LF>.
Print example:
"**0,LB, ,GR,11:08**"
- IDWTTM** This CSV format includes ID, weight, display unit, '\$' if unit is "locked on", weight tag (GR, M+, etc...), date and time.
Ends with a <CR>,<LF>.
Print example:
"FARM 1, 16090,LB, ,GR,27JA00,10:37P"

ANIMAL This CSV format includes information for animal weighing. Includes \$ if unit is "locked-on" weight, weight tag (GR, M+, etc...), display unit, Memory Weight (RM), Average Count (Number of times M+ key was pressed), Average Weight, Gross weight on scale, ID, date and time.

Ends with a <CR>,<LF>.

Print example:

```
" , 1400,GR,LB, 2180, 4, 545,  
1400, ,11:09,13MR02"
```

TROUBLESHOOTING GUIDE

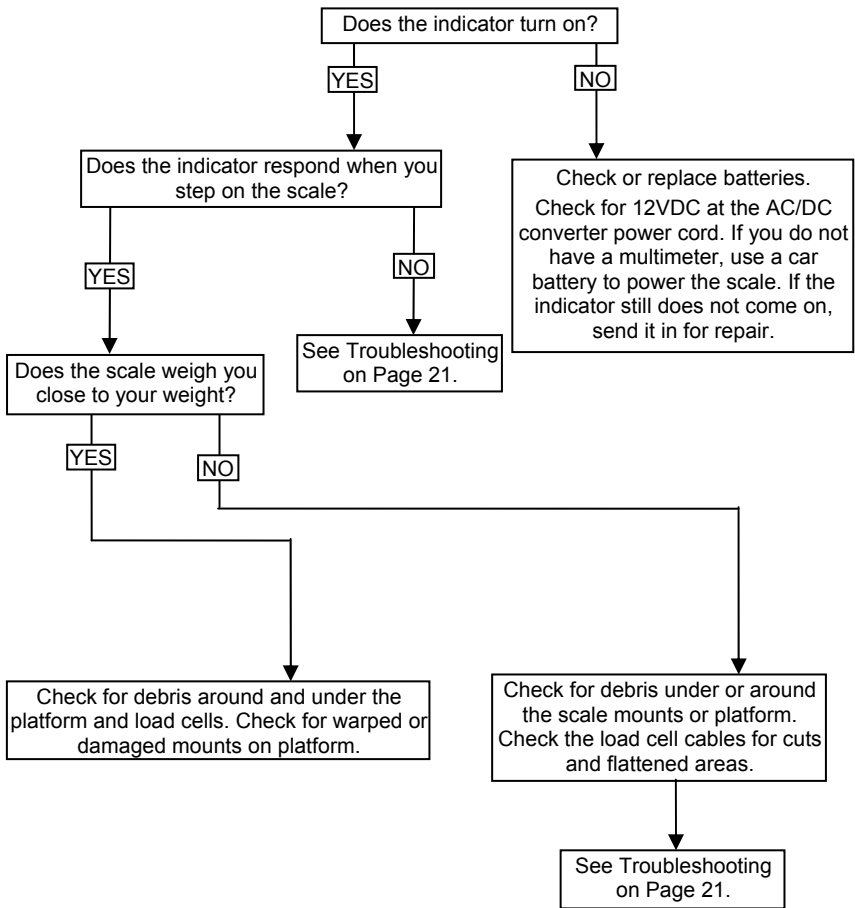

Indicator Does Not Respond When You Step on the Scale

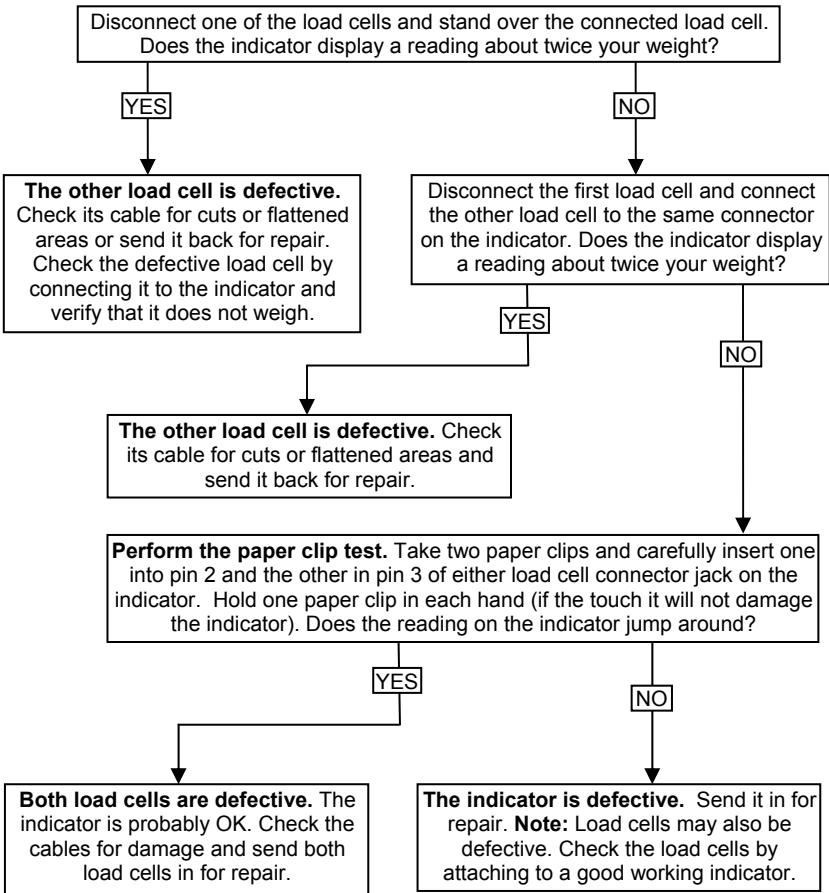

The Scale Weighs Close to Your Weight

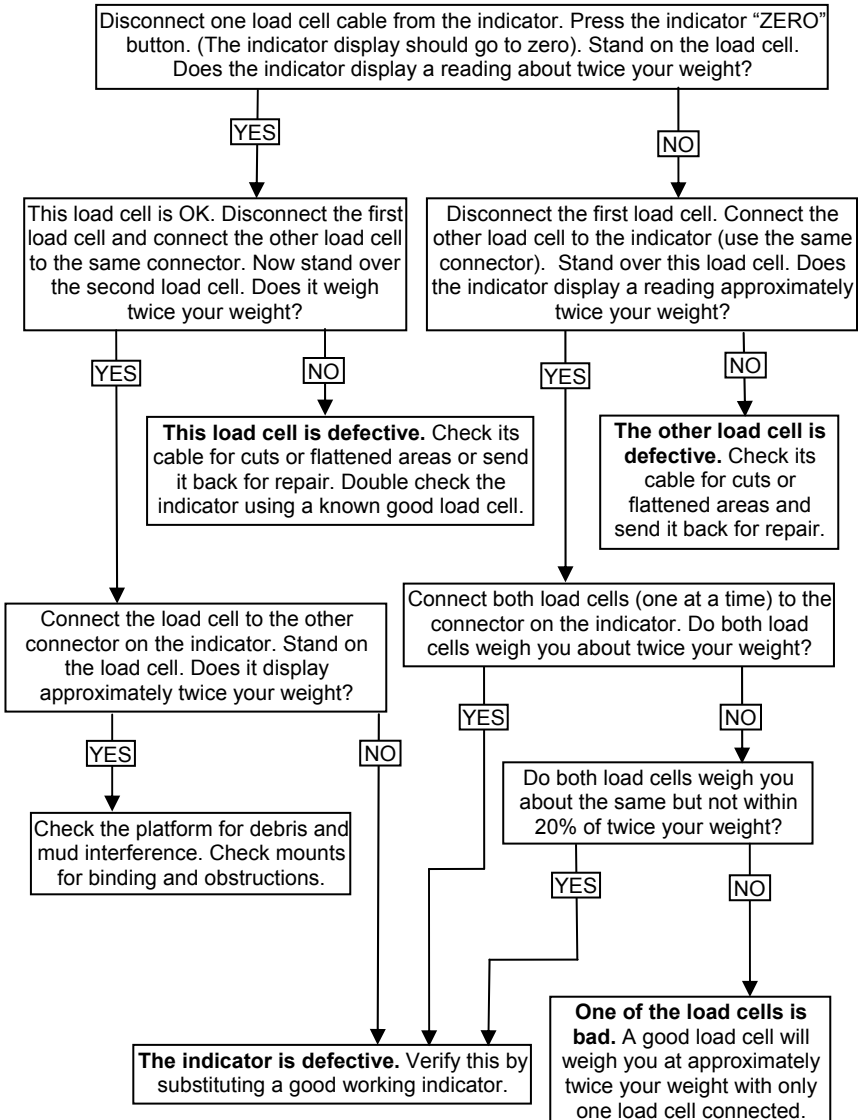

INSTALLATION

Indicator Mounting

RAIL MOUNT		WING MOUNT	WEDGE MOUNT STANDARD
KEY	PART NUMBER	DESCRIPTION	
A	403769	BRACKET – STR TOP MOUNT	
B	403980	BRACKET – ROBO MOUNTING	
C	403770	BRACKET – WING MOUNT	
D	405069	U-BOLT, 1/4-20 X 3.25 ZP	
E	403771	MODIFIED PLASTIC WEDGE MOUNT	
F	405124	WEDGE MOUNT BRACKET, INCLUDES U-BOLTS & NUTS	
G	405084	NUT, 1/4-20 TOP LOCKING FLANGE	

Optional Ram Mounting

RAM MOUNT STANDARD		U-BOLT BASE	TWIST LOCK SUCTION CUP
KEY	PART NUMBER	DESCRIPTION	
A	403180	RAM MOUNT	
B	403179	MOUNT BASE-1" BALL U-BOLT	
C	404230	RAM SUCTION CUP W/TWIST LOCK	

LOAD CELL CONNECTION

Connect load cell wires to terminal blocks.
See Wire Color Key

Wire Color Key		
	Color	Description
1	White	Signal +
2	Green	Signal -
3	Red	Excitation +
4	Black	Excitation -
5	Shield	Shield

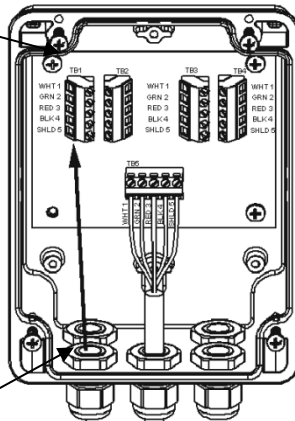

J-Box Illustrated for 4 Load Cell Installation

Tighten nuts

J-Box Cable

Load cell cable

Connect to Indicator bottom panel. See **Error!**